Connected Asset Commissioning, Testing and Information Standard

Contents

Introduction	2
Chapter 1 : Time Frame Requirements	6
Chapter 2 : Code Commissioning Plan Requirements.....	11
Chapter 3 : Asset Capability Statement Requirements.....	13
Chapter 4 : Modelling Requirements	16
Chapter 5 : Connection Study Requirements	21
Chapter 6 : Test Plan Requirements.....	25
Chapter 7 : Testing Requirements	27
Chapter 8 : Operational Communication Requirements	39
Chapter 9 : High Speed Data Requirements	47
Appendix A: Single Line Diagrams	48

Introduction

PURPOSE

1. This is the **connected asset commissioning, testing and information standard (CACTIS)** referred to in Part 8 of the Electricity Industry Participation Code 2010 (**Code**).
2. This **CACTIS** takes effect from [1 July 2026].
3. The purpose of this **CACTIS** is to enable the **system operator** to plan to comply, and comply, with the **principal performance obligations** by specifying requirements relating to:
 - 3.1 the commissioning and testing of **assets**; and
 - 3.2 the information, including modelling information, that **asset owners** must provide to the **system operator**; and
 - 3.3 other operational matters.

INTERPRETATION

4. This **CACTIS** must be read in conjunction with the relevant guidance and forms from time to time **published** by the **system operator**.
5. Any bolded terms in this **CACTIS** that are defined in the **Act** or in Part 1 of the **Code** and that are not defined in this **CACTIS**, have the same meaning as given to them in the **Act** or Part 1 of the **Code** (as applicable).
6. In this **CACTIS**, unless the context otherwise requires, references to paragraphs and Chapters are to paragraphs and Chapters of this **CACTIS**.
7. In this **CACTIS** and the **Code**, unless the context otherwise requires, a reference to an **asset capability statement** for an **asset** means the most recent **asset capability statement** for the **asset** provided to the **system operator** (which may be a **planning stage asset capability statement**, **pre-commissioning stage asset capability statement** or a **final asset capability statement**).
8. In the event of any inconsistency between:
 - 8.1 the provisions of this **CACTIS** and the provisions of the rest of the **Code** (excluding other material incorporated by reference into the **Code**), the provisions of the rest of the **Code** will prevail to the extent of the inconsistency; or
 - 8.2 the provisions of this **CACTIS** and any figure or diagram in this **CACTIS**, the provisions of this **CACTIS** will prevail to the extent of the inconsistency.

DEFINITIONS

In this **CACTIS**, unless the context otherwise requires:

as-left means the final **control system** settings applied to a **control system** after **commissioning**.

asset group 1 means the following **assets** connected or planned to be connected directly or indirectly to the **grid**, including as part of the **grid**:

- (a) **generating stations** with at least one **generating unit** with **rated net maximum capacity** equal to or greater than 1 **MW**; and
- (b) **reactive power** devices with maximum continuous rating equal to or greater than 5 **MVAR**; and
- (c) **assets** owned by **connected asset owners**; and
- (d) **assets** owned by **grid owners**.

asset group 2 means the following **assets** connected or planned to be connected directly or indirectly to the **grid**, including as part of the **grid**:

- (a) **generating stations** that are not **excluded generating stations**; and
- (b) **generating stations** for which the **system operator** requires **offers** or other information under clause 8.25(5) of the **Code**; and
- (c) **dynamic reactive power compensation devices** with maximum continuous rating equal to or greater than 10 **MVAR**.

battery energy storage system or **BESS** means an **energy storage system** with an electro-chemical storage component.

benchmarking means comparing an **asset** model's response against different models of the **asset** using **as-left control system** settings that have been **validated**.

Code commissioning plan means a plan for the **commissioning** of an **asset** that complies with the specifications in Chapter 2.

connection study report means a report on connection study cases for an **asset** that complies with the specifications in Chapter 5.

Code decommissioning plan means a plan for the **decommissioning** of an **asset** that complies with the specifications in paragraphs 1.20, 1.21, and 1.22.

encrypted means a control system model in which the control block(s) and signal flow are accessible, but the logic, mathematical equations, **engineering methodology** and programming code are not accessible to the **system operator**.

end of commissioning period means the point at which all testing of an **asset** has been completed in accordance with the **Code commissioning plan** for the **asset**.

engineering methodology means a document that includes a full description of all tests to be performed on an **asset** including the methodology for each test, the signals to be recorded, the sampling rates to be used, and the format for submitting test results to the **system operator**.

final asset capability statement means an **asset capability statement** prepared at the completion of **commissioning** of an **asset** that complies with the requirements in Chapter 3.

final compliance assessment means a compliance assessment for an **asset** provided by the **system operator** to the **asset owner** under paragraphs 1.18 and 1.19.

final copy means the final version of a document or model that is complete, takes into account all feedback from relevant parties and is ready for sign-off.

final Code decommissioning plan means a plan submitted to the system operator under paragraph 1.20.

generating system means a group of **generating units electrically connected** to a **network** through a common circuit breaker, excluding a **grid interface** circuit breaker.¹

m1 model means a model for an **asset** that complies with the m1 specifications in Chapter 4.

m2 model means a model for an **asset** that complies with the m2 specifications in Chapter 4.

planning stage asset capability statement means an **asset capability statement** prepared prior to the completion of planning for the construction or modification of an **asset** that complies with the specifications in Chapter 3.

pre-commissioning stage asset capability statement means an **asset capability statement** prepared at the completion of construction or modification of an **asset** that complies with the specifications in Chapter 3.

start of commissioning period means the first time a new or modified **asset** is **electrically connected** to a **network**.

state of charge means the amount of energy stored in a **BESS**, expressed as a percentage of its nameplate energy rating (expressed in **MWh**).

test plan means an operational test plan for an **asset** to inform the **system operator** of the timing and details of testing during which the **asset** is **electrically connected** to a **network**.

¹ Refer to the single-line diagrams in Appendix A for further guidance.

unencrypted means a control system model in which all of the control blocks, logic, mathematical equations, signal flows, and programming code are accessible to the **system operator**.

validation means comparing an **asset** model's response against test results, using **as-left control system** settings.

Chapter 1: Time Frame Requirements

- 1.1 This Chapter applies to all **assets** and **asset owners** to which this CACTIS applies.
- 1.2 This Chapter specifies the time frames in which an **asset owner** must provide the **system operator** with the documentation and information required by this **CACTIS** and the **Code** before and after **commissioning** an **asset** and when an **asset** is **decommissioned**.
- 1.3 This Chapter also specifies the time frames in which the **system operator** must review (which includes providing written feedback on) and agree the documentation and information provided to it by an **asset owner** in accordance with this **CACTIS** and the Code before and after the **commissioning** of an **asset** and when an **asset** is **decommissioned**.
- 1.4 If, following review by the **system operator** of any documentation or information provided by an **asset owner** under this **CACTIS**, the **system operator** requires further information from the **asset owner** or the **system operator** is otherwise not satisfied that the documentation or information provided by the **asset owner** meets the relevant requirements set out in this **CACTIS**:
 - (a) the **system operator** (acting reasonably) may request that the **asset owner** provide additional information as necessary or amend and resubmit the relevant documentation or information to the **system operator** for further review; and
 - (b) the **asset owner** must comply with the **system operator's** request within a time frame agreed between the **system operator** and **asset owner** or, failing agreement, within a time frame determined by the **system operator** (acting reasonably); and
 - (c) for the purposes of assessing the **asset owner's** and **system operator's** compliance with the time frame in this **CACTIS** for providing the relevant documentation or information, providing the relevant agreement, or completing the relevant review:
 - (i) the **asset owner** will be deemed not to have provided the **system operator** with the documentation or information until the **asset owner** complies with the **system operator's** request; and
 - (ii) the **system operator** will be deemed not to have provided its agreement, or completed its review, until the **asset owner** receives written notice of this from the **system operator**.
- 1.5 The time frames in this Chapter for an **asset owner** to provide the **system operator** with documentation and information are expressed as a number of months in advance of certain milestones in the **commissioning** process of the relevant **asset**. Except in emergencies, the **asset owner** must not, without the **system operator's** prior written approval, allow a **commissioning** milestone for the **asset** to occur at a time that would mean the **asset owner** did not comply with a time frame in this Chapter for providing the **system operator** with documentation and information about the **asset**.

- 1.6 The **system operator** has agreed, and may in future agree, with the **grid owner** time frames for documentation and information about **grid assets** that are different to the time frames in this Chapter. Those agreements prevail over anything inconsistent in this Chapter, other than time frames for the documentation and information required under Chapters 7 and 8, which the **grid owner** must comply with (except in emergencies).

BEFORE COMMISSIONING

- 1.7 A **planning stage asset capability statement** for an **asset** must be:
- (a) provided by the **asset owner** to the **system operator** at least 5 months prior to when the **asset** is **electrically connected** to a **network**; and
 - (b) reviewed by the **system operator** within 20 **business days** of receiving the **planning stage asset capability statement**.
- 1.8 A **pre-commissioning stage asset capability statement** for an **asset** must be:
- (a) provided by the **asset owner** to the **system operator** at least 2 months prior to when the **asset** is **electrically connected** to a **network**; and
 - (b) reviewed by the **system operator** within 20 **business days** of receiving the **pre-commissioning stage asset capability statement**.
- 1.9 Communication paths for data transmission and a **final copy** of datasets for the provision of **SCADA** and **dispatch** signals must be provided by the **asset owner** to the **system operator** at least 4 months prior to when an **asset** is **electrically connected** to a **network**.
- 1.10 A **final copy** of a **Code commissioning plan** for an **asset** must be:
- (a) provided by the **asset owner** to the **system operator** at least 2 months prior to when the **asset** is **electrically connected** to a **network**; and
 - (b) agreed by the **system operator** within 20 **business days** of receiving the **final copy** of the **Code commissioning plan**.
- 1.11 A **final copy** of the **m1 model** for an **asset** must be:
- (a) provided by the **asset owner** to the **system operator** at least 2 months prior to when the **asset** is **electrically connected** to a **network**; and
 - (b) reviewed by the **system operator** within 20 **business days** of receiving the **final copy** of the **m1 model**.
- 1.12 A **final copy** of a **connection study report** for an **asset** must be:
- (a) provided by the **asset owner** to the **system operator** at least 2 months prior to when the **asset** is **electrically connected** to a **network**; and

- (b) agreed by the **system operator** within 20 **business days** of receiving the **final copy** of the **connection study report**.
- 1.13 A **final copy** of an **engineering methodology** for an **asset** must be:
 - (a) provided by the **asset owner** to the **system operator** at least 2 months prior to when the **asset** is **electrically connected** to a **network**; and
 - (b) agreed by the **system operator** within 20 **business days** of receiving the **final copy** of the **engineering methodology**.
- 1.14 A **test plan** for an **asset** must be:
 - (a) provided by the **asset owner** to the **system operator** at least 15 **business days** prior to when the **asset** is **electrically connected** to a **network**. However, this time frame does not apply to a resubmitted **test plan** for an **asset** in which the only changes are changes to the dates on which the testing is planned to take place or be repeated, provided those dates are not earlier than the dates in the **test plan** as originally submitted or previously resubmitted; and
 - (b) agreed by the **system operator** before the **asset** is **electrically connected** to the **network**.
- 1.15 The following requirements in relation to an **asset** must be demonstrated to the **system operator** at least 10 **business days** prior to when the **asset** is **electrically connected** to a **network**:
 - (a) **Dispatch** communications for the **asset** are operational.
 - (b) Protection coordination for the **asset** at the **grid interface** is confirmed in writing by each **participant electrically connected** to a **network** at the relevant **point of connection** in the format agreed by the **grid owner**.

AFTER COMMISSIONING

- 1.16 A **final asset capability statement** and a full set of test results for an **asset** must be:
 - (a) provided by the **asset owner** to the **system operator** within 20 **business days** of the **end of commissioning period**; and
 - (b) reviewed by the **system operator** within 20 **business days** of receiving the **final asset capability statement**.
- 1.17 A **final copy** of a **m2 model** for an **asset** must be:
 - (a) provided by the **asset owner** to the **system operator** within 3 months of the **end of commissioning period** for the **asset**; and
 - (b) reviewed by the **system operator** within 20 **business days** of receiving the **final copy** of the **m2 model**.

- 1.18 The **system operator** must provide the **asset owner** with a **final compliance assessment** for an **asset** within 4 months of the **end of commissioning period** for the **asset**, subject to the **asset owner**:
- (a) meeting the requirements of paragraphs 1.14 and 1.15; and
 - (b) providing the **system operator** with any additional documentation or information reasonably requested by the **system operator** for the purpose of issuing the **final compliance assessment**.
- 1.19 The **final compliance assessment** for an **asset** must:
- (a) confirm that the **asset** meets the requirements of the **asset owner performance obligations** and **technical codes**; and
 - (b) be based on the documentation and information supplied by the **asset owner**, including (where applicable):
 - (i) the **final asset capability statement**; and
 - (ii) all modelling information; and
 - (iii) the results of **system tests** undertaken during **commissioning**.

DECOMMISSIONING

- 1.20 A **final copy** of a **decommissioning plan** for an **asset** must be:
- (a) provided by the **asset owner** to the **system operator** at least 2 months prior to permanently **electrically disconnecting** the **asset** from a **network**.
 - (b) agreed by the **system operator** within 20 **business days** of receiving the **final copy** of the **decommissioning plan**.
- 1.21 The **final copy** of the **decommissioning plan** for an **asset** must confirm:
- (a) the date the **asset** was, or will be, **decommissioned**; and
 - (b) the date the **asset** will be permanently **electrically disconnected** from a **network**; and
 - (c) the date that all the **system operator's** tools should be updated to record the **decommissioning** and permanent **electrical disconnection** of the **asset**.
- 1.22 The **asset owner** must provide the **system operator** with an update to the **asset capability statement** for a **decommissioned asset** within 2 weeks of **decommissioning** the **asset**.

Figure 1: Timeline of Commissioning Requirements

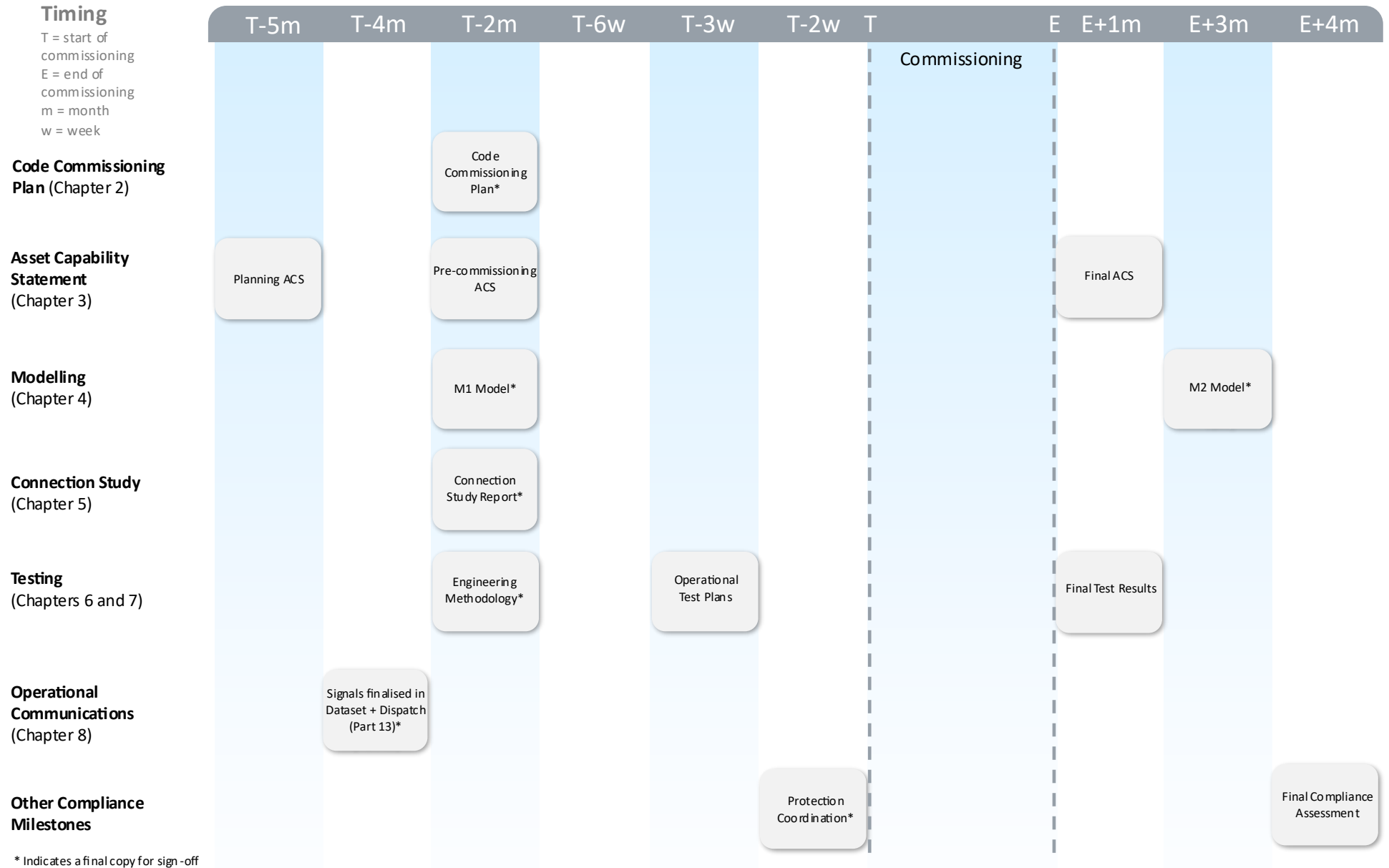

* Indicates a final copy for sign-off

Chapter 2: Code Commissioning Plan Requirements

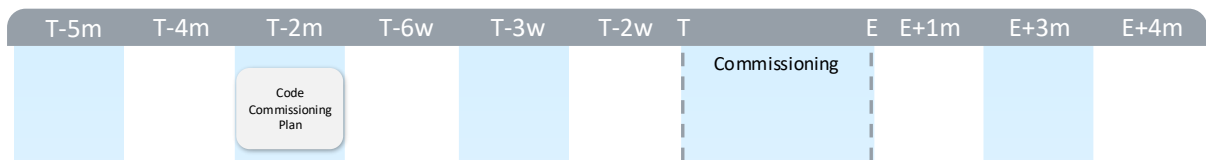

2.1 This Chapter applies to:

- (a) **assets** in **asset group 2**; and
- (b) **assets** not in **asset group 1** or **asset group 2** that are referred to specifically in this Chapter; and
- (c) any other **asset** that does not form part of the **grid** and is to be connected to a **network**, or changed, or proposed to be changed, in a way that alters any of the following at the **grid interface**:
 - (i) the **single-line diagram**; or
 - (ii) a protection system, other than a change to a protection system setting; or
 - (iii) a **control system**, including a change to a **control system** setting or firmware; or
 - (iv) any rating of the **asset**; and
- (d) the **asset owners** of these **assets**.

2.2 This Chapter specifies the requirements for **Code commissioning plans** that must be provided by an **asset owner** to the **system operator** under clause 2(6) of **Technical Code A** of Schedule 8.3 of the **Code**.

2.3 The **asset owner** must provide a **Code commissioning plan** for an **asset**:

- (a) in the form from time to time **published** by the **system operator**; and
- (b) in accordance with the time frame in Chapter 1.

2.4 The **asset owner** must provide a **Code commissioning plan** for an **asset** in the following situations:

- (a) when the **asset** is to be **electrically connected** to a **network**; and
- (b) when changes are made to the **asset** that alter any of the following at the **grid interface**:
 - (i) the **single-line diagram**; or
 - (ii) a protection system, other than a change to a protection system setting; or

- (iii) a **control system**, including a change to a **control system** setting or firmware; or
- (iv) any rating of the **asset**.

2.5 The **asset owner** must contact the **system operator** for advice if:

- (a) the **commissioning** or **electrical connection** of an **asset** may affect the **system operator's** ability to plan to comply, or to comply, with the **principal performance obligations**; or
- (b) the **asset owner** is unsure whether the **commissioning** or **electrical connection** of the **asset** may affect the **system operator's** ability to plan to comply, and to comply, with the **principal performance obligations**.

2.6 A **Code commissioning plan** for an **asset** must:

- (a) include a timetable containing the sequence of events necessary to **electrically connect** the **asset** to a **network** and undertake any proposed test; and
- (b) contain the protection and control settings to be applied before the **asset** is **electrically connected** to, or becomes part of, a **network**; and
- (c) contain the procedures for **commissioning** the **asset** with minimum risk to personnel and plant and to the ability of the **system operator** to plan to comply, and to comply, with the **principal performance obligations**; and
- (d) contain all other information required by the form for the **Code commissioning plan** from time to time **published** by the **system operator**.

Chapter 3: Asset Capability Statement Requirements

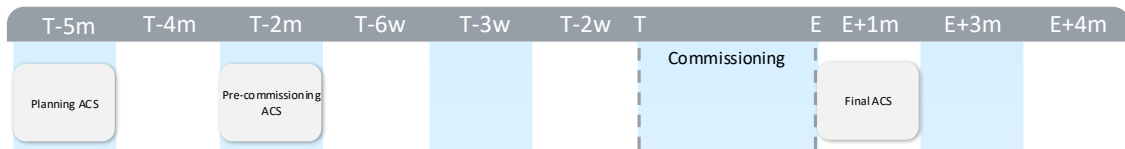

- 3.1 This Chapter applies to **assets** in **asset group 1** and **asset group 2** and their **asset owners**.
- 3.2 This Chapter specifies the requirements for **asset capability statements** that must be provided by an **asset owner** to the **system operator** under clause 2(5) of **Technical Code A** of Schedule 8.3 of the Code.
- 3.3 The **asset owner** must provide each **asset capability statement** for an **asset**:
 - (a) in the form from time to time specified by the **system operator**; and
 - (b) in accordance with the relevant time frame in Chapter 1.
- 3.4 For the purpose of clause 2(5) of **Technical Code A** of Schedule 8.3 of the Code, an **asset capability statement** for an **asset** must:
 - (a) include the following information:
 - (i) if the **asset capability statement** is a **planning stage asset capability statement**:
 - (A) if the **asset** is a **generating station**, information relating to **generating station** capability and connection topology; and
 - (B) (as applicable) details of transmission line, **generating unit**, transformer, **battery energy storage system**, and **reactive power** device capabilities; or
 - (ii) if the **asset capability statement** is a **pre-commissioning stage asset capability statement**:
 - (A) all information contained in the **planning stage asset capability statement** (updated as necessary to reflect changes to the **asset** at the pre-commissioning stage); and
 - (B) as-built or site-specific data relating to the **asset**; and
 - (C) any modelling data required by and prepared in accordance with Chapter 4; and
 - (D) any connection studies required by and prepared in accordance with Chapter 5; or

(iii) If the **asset capability statement** is a **final asset capability statement**:

- (A) all information contained in the **pre-commissioning stage asset capability statement** (updated as necessary to reflect changes to the **asset** at the post-commissioning stage); and
- (B) **as-left control system** settings relating to the **asset**; and

- (b) be updated as information and design development progresses through the study, design, manufacture, testing and **commissioning** phases for the **asset**; and
- (c) always be complete and up to date while the **asset** is **electrically connected** to a **network**.

3.5 If there is any change to the capability of an **asset** that may affect either the **asset owner's** ability to meet its **asset owner performance obligations** or the **system operator's** ability to meet the **principal performance obligations**, the **asset owner** must:

- (a) notify the **system operator** immediately and update the **asset's asset capability statement** within 5 **business days** of the change; or
- (b) where the change is urgent or temporary (less than 4 weeks), promptly notify the **system operator** in written form of the change using the form from time to time **published** by the **system operator**. For the purposes of this paragraph, an urgent or temporary change in **asset** capability is a change where the **asset owner**:
 - (i) unexpectedly becomes aware that the capability of the **asset** may differ from the capability described in the **asset's asset capability statement** and there is no practicable opportunity to update the **asset capability statement** in accordance with this **CACTIS**; and
 - (ii) the **asset owner** needs to perform further investigations to determine or confirm the capability of the **asset** after the change.

3.6 When the **asset owner** updates an **asset capability statement** for an **asset**:

- (a) the **system operator** must assess, based on the information in the updated **asset capability statement**, whether the **asset** is consistent with the **asset owner's asset owner performance obligations** and provide written feedback to the **asset owner** within 20 **business days** of receiving the update; and
- (b) if required by the **system operator**, the **asset owner** must provide the **system operator** with a further updated **asset capability statement** for the **asset** addressing the **system operator's** feedback in a time frame agreed between the **system operator** and **asset**

Electricity Industry Participation Code – dd MMM yyyy

owner or, failing agreement, determined by the **system operator** (acting reasonably).

Chapter 4: Modelling Requirements

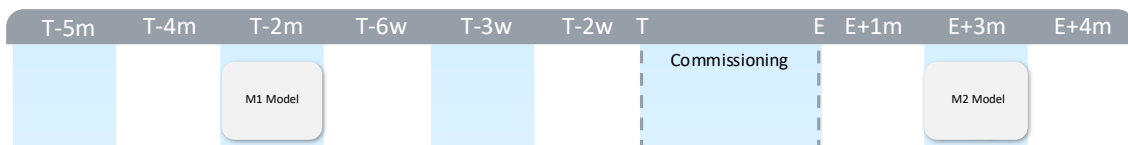

- 4.1 This Chapter applies to **assets** in **asset group 2** and their **asset owners**.
- 4.2 This Chapter specifies the requirements for modelling data that must be provided by **asset owners** to the **system operator** and under clauses 2(10)(c) and 2(10)(d) of **Technical Code A** of Schedule 8.3 of the **Code** and in connection with other requirements in this **CACTIS**.

M1 AND M2 MODELS

- 4.3 An **asset owner** must provide an **m1 model** and an **m2 model** at the times specified in Chapter 1.
- 4.4 An **m1 model** is a connection study model where all the site-specific settings and control modes are modelled with the **control system** and the protection systems, with appropriate settings. The protection system must include, at a minimum, frequency and voltage protection functions.
- 4.5 An **m2 model** is a final validated model where all the site-specific settings with the intended control mode and transition between controls are included. The control system must be in the model with **as-left** settings. The protection system must include, at a minimum, frequency and voltage protection functions.

SOFTWARE PACKAGES, FORMATS, AND CONFIDENTIALITY

- 4.6 All **m1 models** and **m2 models** must be provided to the **system operator** in the following software packages and model formats:
- (a) For a synchronous **generating unit**, both the **m1 model** and **m2 model** must use PowerFactory.
 - (b) For a **generating unit** producing power from wind or solar irradiance or a **BESS**:
 - (i) the **m1 model** must use:
 - (A) PowerFactory; and
 - (B) Power System Computer Aided Design (PSCAD).
 - (ii) the **m2 model** must use:
 - (A) PowerFactory, and must be **unencrypted**; and
 - (B) Powertech's Transient Security Assessment Tool (TSAT); and
 - (C) PSCAD.

- 4.7 If an **asset owner** provides an **unencrypted** model to the **system operator**, the model must be in one of the following formats:
- (a) a model block diagram format, where the model is prepared with basic control blocks and graphical representation of control system components. PowerFactory, PSCAD, and TSAT models must have the control blocks, logic, mathematical equations, signal flows and programming code accessible to the **system operator**; or
 - (b) a model source code format, where the model is prepared with programming codes written and organised to implement control system functions.
- 4.8 If an **asset owner** provides an **encrypted** PSCAD and TSAT model (or **encrypted** parts of a PSCAD and TSAT model) to the **system operator**, the **asset owner** must make the outputs and inputs of the **encrypted** model (or part thereof) accessible to the **system operator**, and the function of the **encrypted** model (or part thereof) must be explained in the supporting documentation.
- 4.9 If an original equipment manufacturer deems a model is not to be shared publicly, then in addition to the **m1 model** and **m2 model**, the **asset owner** must also provide the **system operator** with a PowerFactory or a Western Electricity Coordinating Council (WECC) generic model, which can be shared publicly by the **system operator**.

GENERAL MODEL CONFIGURATION REQUIREMENTS

- 4.10 An **asset owner** must provide the **m1 model** and **m2 model** suitable for root mean square (RMS), positive phase-sequence, time domain and electromagnetic transient (EMT) studies. The **system operator** must use these to:
- (a) assess the **asset's** capability to meet the corresponding **Code** obligations; and
 - (b) carry out other power system studies such as system security, short-term operation planning, stability, and post-event investigation assessments.
- 4.11 All models an **asset owner** provides to the **system operator** must:
- (a) have a degree of adequacy and accuracy that allows the **system operator** to make informed decisions based on simulation results; and
 - (b) be site-specific; and
 - (c) represent the dynamic behaviour of the **asset**, including all elements and control systems that affect the **active power** and **reactive power** output of the **asset** in response to frequency and voltage changes at the **point of connection**. The **asset** must be modelled according to its type, as follows:
 - (i) a synchronous **generating station** must be modelled as a full **generating station**, including individual **generating**

units, generating unit transformers and **generating station** auxiliary loads; and

- (ii) a **generating station** producing power from wind or solar irradiance or a **BESS** can be aggregated with **generating units** of the same design into a single **generating unit** to accurately represent the overall performance of the **generating units** at a common **point of connection**. A representation of the collector system, inverter transformer, **grid** tie transformer and any additional **dynamic reactive power compensation devices** must be included in the aggregated model; and
- (d) represent all control modes within the frequency and voltage **control system**, ensuring they can be used in real-time operation and can accept external signals to trigger changes; and
- (e) not contain any unused control blocks or programme codes; and
- (f) allow the **system operator** access to, and visibility of, all control signals and equations used to initialise the model; and
- (g) be compatible with the modelling software package versions from time to time **published** by the **system operator**.

POWERFACTORY AND TSAT MODEL REQUIREMENTS

4.12 A PowerFactory or TSAT model submitted by an **asset owner** to the **system operator** must:

- (a) be numerically stable for the full operating range, which must be at least a frequency range of 45 Hertz to 55 Hertz and at least a voltage range of 0 pu to 1.3 pu; and
- (b) be numerically stable for a simulation time of at least 120 seconds, with voltage, frequency, **active power** and **reactive power** remaining constant with no disturbance; and
- (c) be numerically stable for a minimum of 60 seconds following any set point changes or contingency; and
- (d) be operationally stable with an integration time step that is a minimum of 5 milliseconds; and
- (e) have key settings such as droop setting, ramp rate and state of charge for **BESS** and hybrid plants available for the **system operator** to change.

PSCAD MODEL REQUIREMENTS

4.13 A PSCAD model submitted by an **asset owner** to the **system operator** must:

- (a) be developed with adequate details to represent the complete behaviour of the control system; and
- (b) include suitable phase-locked loop (PLL), inner current controls and protection settings; and

- (c) have key settings including droop setting, dead band and ramp rate available for users to change; and
- (d) initialise correctly and match closely the desired power flow solution; and
- (e) initialise within 3 seconds of the start of a simulation and have snapshot capability; and
- (f) support a 10 microsecond or greater simulation time step and be stable for at least 30 seconds of simulation time under no disturbance conditions.

MODEL VALIDATION

- 4.14 The **asset owner** must **validate** PowerFactory and PSCAD models against test results recorded during **commissioning** of the **asset** to confirm accuracy and reliability of the **as-left control system** settings.
- 4.15 The **asset owner** must benchmark a TSAT model against a PSCAD **validated** model of the **asset**.

MODEL DOCUMENTATION

- 4.16 The **asset owner** must supplement each model provided to the **system operator** with documentation that includes the following:
 - (a) a full description of the model and its functionality, including transfer function block diagram, signal description, mapping, and calculations; and
 - (b) instructions on the use and operation of the model, including operational limitations; and
 - (c) descriptions of the parameters available for the **system operator** to monitor; and
 - (d) details of the aggregation method and functional block diagrams; and
 - (e) descriptions of the control functions and any specific features of the models like fault ride through control or PLL operation; and
 - (f) values and ranges of all configurable settings, and their impact on the **control system** performance; and
 - (g) cross-referencing between the PowerFactory and TSAT model control blocks and the PSCAD model control blocks; and
 - (h) limitations of the models and dependencies on compiler or software operating environments; and
 - (i) instructions to re-compile the model, for when the **system operator** migrates to new software package versions.

MODEL MAINTENANCE AND UPDATE

- 4.17 For the purposes of clause 2(10)(c) of **Technical Code A** of Schedule 8.3 of the **Code**, the **asset owner** must:
- (a) following notification by the **system operator** of an upgrade to its software package version, provide (as necessary) updated models to the **system operator** compatible with the updated software package version; and
 - (b) following an event investigation by the **system operator** that identifies any shortfall in one or more models, provide (as necessary and if requested by the **system operator**) updated models to the **system operator** to address the shortfall.
- 4.18 If an **asset owner** receives a notification or request from the **system operator** under paragraph 4.17, the **asset owner** must provide the necessary updated models to the **system operator** within 3 months of receiving the notification or request, or within a different time frame agreed with the **system operator**.
- 4.19 The **asset owner** must **validate** and submit to the **system operator** a new model for an **asset** in the following situations:
- (a) when any change to the **asset** alters its performance; and
 - (b) after the completion of routine testing of the **asset** in accordance with Chapter 7, where the **asset's** performance has changed.
- 4.20 If, after the completion of routine testing of the **asset**, the performance of the **asset** has not changed, the **asset owner** must submit to the **system operator** an updated **validation** report incorporating the existing model and most recent routine test results.

Chapter 5: Connection Study Requirements

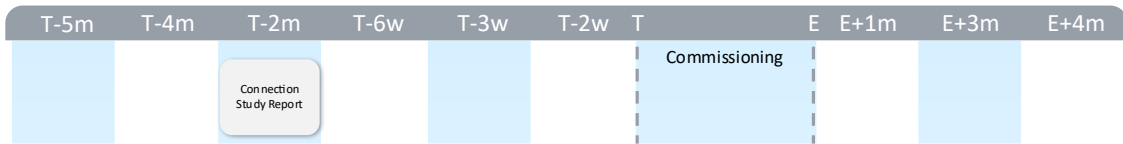

- 5.1 This Chapter applies to **assets** in **asset group 2** and their **asset owners**.
- 5.2 This Chapter specifies the requirements for connection studies that must be undertaken by **asset owners** and **connection study reports** that **asset owners** must submit to the **system operator** under clause 2(10)(a) and 2(10)(b) of **Technical Code A** of Schedule 8.3 of the **Code**.

GENERAL CONNECTION STUDY REQUIREMENTS

- 5.3 **Asset owners** must submit **connection study reports** to the **system operator**:
 - (a) in accordance with the time frames in Chapter 1; and
 - (b) together with the **m1 model** and supporting documents for the **asset**.
- 5.4 The **asset owner** must comply with the following requirements for connection studies for an **asset**:
 - (a) The **asset owner** must undertake (and include in the **connection study report** the results of) a power-flow study.
 - (b) If the **asset owner** has or will have frequency support obligations in respect of the **asset**, the **asset owner** must undertake (and include in the **connection study report** the results of) the following connection studies:
 - (i) Frequency regulation and tuning study; and
 - (ii) Short circuit study; and
 - (iii) Transient stability study.
 - (c) If the **asset owner** has or will have voltage support obligations in respect of the **asset**, the **asset owner** must undertake (and include in the **connection study report** the results of) the following connection studies:
 - (i) **Reactive power** capability study; and
 - (ii) Voltage regulation and tuning study; and
 - (iii) Short circuit study; and
 - (iv) Transient stability study.

- (d) If an **asset owner** has or will have fault ride through obligations in respect of the **asset**, the asset owner must undertake (and include in the **connection study report** the results of) the following connection studies:
 - (i) Short circuit study; and
 - (ii) Fault ride through study; and
 - (iii) Transient stability study.

5.5 The **asset owner** must identify and explain in the **connection study report** for an **asset** any behaviour that is non-compliant or potentially non-compliant with Part 8 of the Code observed for the **asset** in any connection study.

POWER-FLOW STUDY

5.6 A power-flow study must be undertaken to ensure the **asset** does not overload existing power system equipment or impose operational constraints under normal conditions and outage conditions.

5.7 A power-flow study must cover a minimum 3-year horizon.

REACTIVE POWER CAPABILITY STUDY

5.8 A **reactive power** capability study must be undertaken while the **asset** is generating at 100%, 50%, and 30% **active power** levels.

5.9 If the **asset** is a **BESS**, the **reactive power** capability study must also be undertaken while the **asset** is charging at 100%, 50%, and 30% **active power** levels.

FREQUENCY REGULATION AND TUNING STUDY

5.10 A frequency regulation and tuning study must be undertaken to assess the frequency regulation performance of the **asset** in the context of major power system disturbances, including the **electrical disconnection** of:

- (a) the largest **generating unit** connected to the **grid** in the **island** in which the **asset** is proposed to be connected or is connected; and
- (b) the **HVDC link** bipole.

5.11 The stability of the **asset's** frequency **control system** and suitability of that system's settings must be assessed during the frequency regulation and tuning study.

VOLTAGE REGULATION AND TUNING STUDY

5.12 A voltage regulation and tuning study must be undertaken to assess the voltage regulation performance of the **asset** in the context of voltage disturbances caused by factors such as tripping of other **assets** that are electrically close to the **asset**.

- 5.13 The stability of the **asset's** voltage **control system** and suitability of that voltage **control system's** settings must be assessed in conjunction with other **assets**, including **dynamic reactive power compensation devices**.
- 5.14 The voltage regulation and tuning study must include:
- (a) Power System Stabiliser (PSS) or Power Oscillation Damper (POD), as applicable; and
 - (b) over- and under-excitation limiters; and
 - (c) over- and under-voltage protection.

SHORT CIRCUIT STUDY

- 5.15 A short circuit study must be undertaken to determine the Effective Short Circuit Ratio (ESCR) at the **asset's point of connection** under the following operating conditions:
- (a) Covering a minimum 3-year horizon; and
 - (b) Full intact power system and n-1-1 outage scenarios; and
 - (c) Maximum and minimum short circuit levels at the **point of connection** and nearby electrical busbars under various power system conditions, including relevant power system reconfigurations.

TRANSIENT STABILITY STUDY

- 5.16 For a synchronous **generating unit**, a transient stability study must be undertaken to determine the Critical Fault Clearing Time (CFCT) by applying a three phase-to-ground fault at the **generating unit's point of connection**.
- 5.17 For a **generating unit** producing power from wind or solar irradiance or a **BESS**, a transient stability study must be undertaken by applying an unbalanced fault to assess the ability of the **generating unit's** inverter to recover and remain stable after the fault has been removed.

FAULT RIDE THROUGH STUDY

- 5.18 The **asset owner** must finalise all of the **control system** settings for an **asset** before undertaking fault ride through studies for the **asset**.
- 5.19 If the **asset owner** modifies any of the **control system** settings for the **asset** during the fault ride through studies, the **asset owner** must notify the **system operator** and the fault ride through studies must be repeated with the new **control system** settings.
- 5.20 For a synchronous **generating unit**, the **asset owner** must undertake fault ride through studies with PowerFactory RMS simulations.
- 5.21 For a **generating unit** producing power from wind or solar irradiance or a **BESS**, the **asset owner** must undertake fault ride through studies as follows:

- (a) undertake a PowerFactory RMS simulation as an initial screening to cover all generation scenarios, fault types and **asset** operation conditions agreed with the **system operator**; and
 - (b) undertake a PSCAD study to assess a selection of study cases identified in the PowerFactory RMS simulation, as agreed with the **system operator**.
- 5.22 If the **asset owner** modifies any of the **control system** settings for the **asset** during or after **commissioning**, the **asset owner** must notify the **system operator** and the fault ride through studies must be repeated with the new **control system** settings.

SHARING OF ENCRYPTED MODELS FROM OTHER ASSET OWNERS

- 5.23 If a fault ride through study for an **asset** requires the **asset owner** to assess how other **assets** impact the **asset's** fault ride through capabilities, the **asset owner** must either:
- (a) seek consent directly from the other **asset owners** to obtain **encrypted** models of the relevant **assets**; or
 - (b) request the **system operator** seek consent from the other **asset owners** to share their **encrypted** models held by the **system operator** with the **asset owner**.
- 5.24 The **asset owner** must use the **encrypted** models obtained under paragraph 5.23 solely for the purpose of fault ride through studies for the **asset**.

Chapter 6: Test Plan Requirements

6.1 This Chapter applies to:

- (a) **assets** in **asset group 2**; and
- (b) assets not in **asset group 1** or **asset group 2** that are referred to specifically in this Chapter; and
- (c) any other **asset** that does not form part of the **grid** and is to be connected to a **network**, or changed, or proposed to be changed, in a way that alters any of the following at the **grid interface**:
 - (i) the **single-line diagram**; or
 - (ii) a protection system, other than a change to a protection system setting; or
 - (iii) a **control system**, including a change to a **control system** setting or firmware; or
 - (iv) any rating of the **asset**; and
- (d) the **asset owners** of these **assets**.

6.2 This Chapter specifies the requirements for **test plans** that must be provided by **asset owners** to the **system operator** under clause 2(6) of **Technical Code A**, Schedule 8.3 of the **Code**.

6.3 **Asset owners** must submit **test plans** to the **system operator** in accordance with the time frames in Chapter 1.

WHEN A TEST PLAN MUST BE PROVIDED

6.4 The **asset owner** must provide a **test plan** to the **system operator** in the following situations:

- (a) when the **asset** is either to be **electrically connected** to, or is to form part of, a **network**, and
- (b) when a change is made to an **asset** that alters any of the following at the **grid interface**:
 - (i) the **single-line diagram**; or
 - (ii) a protection system, other than a change to a protection system setting; or
 - (iii) a **control system**, including a change to a **control system** setting or firmware; or
 - (iv) any rating of **assets**; and
- (c) if it is necessary for the **asset owner** to perform a **system test** or other test to ascertain or confirm **asset** capabilities, and

- (d) if the testing or connection of an **asset** may affect the **system operator's** ability to plan to comply, or to comply with, the **principal performance obligations**; and
- (e) when planned work is to be carried out on an **asset** that affects either the **system operator's** ability to achieve the **dispatch objective** or the accuracy of any operational communications described in Chapter 8.

6.5 For the purposes of clause 2(6) of **Technical Code A** of Schedule 8.3 of the **Code**, a **test plan** must contain:

- (a) the **asset owner's** contact information, including contact person, phone number, email address, and point of contact for the **test plan**; and
- (b) **asset** and test details, including **asset** name, type of test, test date, test time and test duration; and
- (c) description and expected impact of test, including change in **asset** capability, potential risk to the **grid** and expected impact on **asset owner performance obligations**; and
- (d) any other information that the **asset owner** considers could assist the **system operator** to assess the **test plan** or assist the **system operator** in planning to comply, and complying, with the **principal performance obligations**.

Chapter 7: Testing Requirements

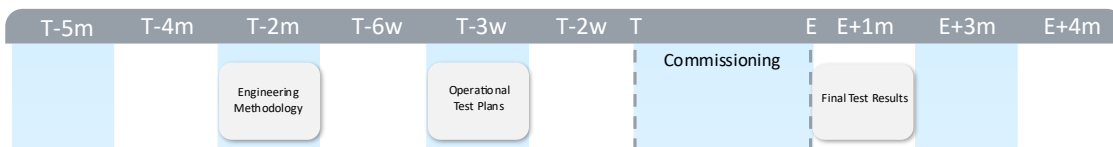

- 7.1 This Chapter applies to:
- assets** in **asset group 2**; and
 - assets not in **asset group 1** or **asset group 2** that are referred to specifically in this Chapter; and
 - the **asset owners** of these **assets**.
- 7.2 This Chapter specifies the requirements for testing that must be undertaken by **asset owners** and communicated to the **system operator** under clauses 8(2)(a) and 8(3) of **Technical Code A** of Schedule 8.3 of the **Code**.
- 7.3 **Asset owners** must undertake testing in accordance with the time frames in this Chapter and in Chapter 1.
- 7.4 **Asset owners** must submit all test results required in this Chapter, including for routine testing, and:
- update the **asset capability statement** within **20 business days** of the completion of testing; and
 - provide the **system operator** with a **validated m2 model** within 3 months of the completion of testing.

GENERAL REQUIREMENTS

- 7.5 **Asset owners** must fulfil the requirements in this Chapter when undertaking testing for new or modified **assets** that are being **commissioned**, and for routine and remedial testing.
- 7.6 As required by clause 8(2A) of Technical Code A of the Code, each **asset owner** with one or more **generating units commissioned** before 1 January 2016 for which wind is the primary power source must complete the first of each test required in this Chapter for those **generating units** no later than 31 December 2028.
- 7.7 If the **system operator** advises an **asset owner** under clause 8(3) of **Technical Code A**, Schedule 8.3 of the Code, the **asset owner** must:
- as soon as practicable, but no later than 30 days after receiving a written request, advise the **system operator** of its remedial or **test plan** for the **asset**; and
 - as soon as reasonably practicable, undertake any remedial action or testing of the **asset** in accordance with its plan advised to the **system operator** under paragraph 7.7(a). The **system operator** may require

such testing or remedial action to be undertaken in the presence of a **system operator** representative.

ENGINEERING METHODOLOGY

- 7.8 An **asset owner** must submit an **engineering methodology** to the **system operator** for review if:
- (a) the **asset owner** intends to **electrically connect** a new **asset** to a **network**; or
 - (b) the **asset owner** intends to modify an existing **asset** that is connected to a **network**; or
 - (c) the **asset owner** is carrying out routine testing of an **asset** and is unsure if its proposed testing will meet the requirements in this Chapter.
- 7.9 The **asset owner** must provide a **final copy** of the **engineering methodology** to the **system operator** in accordance with the time frames in Chapter 1.

REPRESENTATIVE TESTING

- 7.10 Subject to paragraph 7.7, an **asset owner** may provide the information required under paragraphs 7.18(c), 7.18(c), 7.20(c), 7.24(c), 7.26(c), and 7.30(c) to the **system operator**, based on representative modelling settings and response data, instead of based on the tests required under paragraphs 7.18(a) and 7.18(b), 7.20(a) and 7.20(b), 7.24(a) and 7.24(b), 7.26(a) and 7.26(b), and 7.30(a) and 7.30(b), for any group of identical **assets** if each of those **assets**:
- (a) was manufactured to the same specification; and
 - (b) is installed at the same location; and
 - (c) is controlled in the same way; and
 - (d) has a similar maintenance history.
- 7.11 An **asset owner** providing representative modelling settings and response data to the **system operator** in accordance with paragraph 7.10 for a group of identical **assets** must:
- (a) complete a full set of tests in accordance with paragraphs 7.18(a) and 7.18(b), 7.18(a) and 7.18(b), 7.20(a) and 7.20(b), 7.20(a) and 7.20(b), 7.26(a) and 7.26(b), and 7.30(a) and 7.30(b), as applicable, on an **asset** that is representative of that group to derive a verified set of modelling settings and response data; and
 - (b) complete sufficient testing on the remaining **assets** in that group of identical **assets** in accordance with paragraphs 7.18(a) and 7.18(b), 7.18(a) and 7.18(b), 7.20(a) and 7.20(b), 7.20(a) and 7.20(b), 7.26(a) and 7.26(b), and 7.30(a) and 7.30(b), as applicable, to verify that the performance of the remaining **assets** in that group is fully consistent with the modelling settings and response data derived from the tests carried out on the representative **asset**; and

- (c) certify to the **system operator** that, to the best of the **asset owner's** information, knowledge and belief, the performance of that group of **assets** is fully consistent with the representative modelling settings and response data provided to the **system operator** for that group of **assets**.

EVENT DATA IN LIEU OF TESTING

- 7.12 The owner of a **generating station** that exports 10 **MW** or more but less than 30 **MW** to a **network** may update its **asset capability statement** to verify to the **system operator** that the **control system** for the **generating station** meets the requirements of the **asset owner performance obligations** and **technical codes** based upon event data instead of carrying out routine testing, subject to the following conditions being met:
- (a) the event data must be recorded using a **high-speed monitor** that meets the minimum accuracy and refresh rate requirements in Chapter 9; and
 - (b) the event data must be provided within 10 **business days** of the event; and
 - (c) the event must have occurred within the required testing interval in this Chapter.

SPECIFIC TESTING REQUIREMENTS

SHUNT CAPACITORS AND REACTIVE POWER CONTROL SYSTEMS

- 7.13 An **asset owner** with a **shunt** capacitor directly connected to a **network** must:
- (a) test the capacitance of the **shunt** capacitor at least once every 8 years; and
 - (b) test the operation of each of its **asset's** analogue **control systems** at least once every 4 years; and
 - (c) test the operation of each of its **reactive power** control **asset's** digital **control systems** at least once every 10 years; and
 - (d) based on a test carried out in accordance with paragraph 7.13(a), provide a set of test results to the **system operator** in an updated **asset capability statement** within 3 months of the completion date of each such test; and
 - (e) based on a test carried out in accordance with paragraph 7.13(b) or (c), provide a verified set of **control system** test results, including voltage set points, operating dead bands and time delays, to the **system operator** in an updated **asset capability statement** within 3 months of the completion date of each such test.

DYNAMIC REACTIVE POWER COMPENSATION DEVICE TRANSIENT RESPONSE AND CONTROL

- 7.14 An **asset owner** with a **dynamic reactive power compensation device** with rated net maximum capacity equal to or greater than 10 MVar directly connected to a **network** must:
- (a) test the transient response, steady state response and alternating current (AC) disturbance response of the **dynamic reactive power compensation device** at least once every 10 years; and
 - (b) test the operation of the **dynamic reactive power compensation device's** analogue **control systems** at least once every 4 years; and
 - (c) test the operation of the **dynamic reactive power compensation device's** digital **control systems** at least once every 10 years; and
 - (d) based on a test carried out in accordance with paragraph 7.14(a), provide a verified set of modelling parameters, transient response parameters, steady state response parameters, and AC disturbance response data to the **system operator** in an updated **asset capability statement** within 3 months of the completion date of each such test, including:
 - (i) a block diagram showing the mathematical representation of the **dynamic reactive power compensation device**; and
 - (ii) a parameter list showing gains, time constants, limiters and other settings applicable to the block diagrams; and
 - (iii) a detailed functional description of all the components of the **dynamic reactive power compensation device** and how they interact in each mode of control; and
 - (iv) step response test results; and
 - (v) AC fault recovery disturbance test results; and
 - (e) based on the tests carried out in accordance with paragraphs 7.17(b) or 7.17(c), provide a set of **control system** test results to the **system operator** in an updated **asset capability statement** within 3 months of the completion date of each such test.

ALTERNATING CURRENT (AC) PROTECTION SYSTEMS

- 7.15 An **asset owner** must:
- (a) test the operation of the analogue protection systems on its AC **assets** at least once every 4 years; and
 - (b) test the operation of the non-self monitoring digital protection systems on its AC **assets** at least once every 4 years; and
 - (c) test the operation of the self monitoring digital protection systems on its AC **assets** at least once every 10 years; and

- (d) test the operation of the protection system measuring circuits on its AC **assets** by secondary injection at least once every 4 years; and
- (e) test the operation of the protection system trip circuits, including circuit breaker trips, on its AC **assets** at least once every 4 years; and
- (f) confirm at least once every 4 years that its protection settings are identified, co-ordinated, applied correctly and meet the requirements of the **asset owner performance obligations** and the **technical codes**; and
- (g) based on a test carried out in accordance with any of paragraphs 7.15(a) to (e), provide an updated **asset capability statement** within 3 months of the completion date of each such test to verify to the **system operator** the protection systems meet the requirements of the **asset owner performance obligations** and **technical codes**; and
- (h) based on a confirmation carried out in accordance with paragraph 7.15(f), provide an updated **asset capability statement** to the **system operator** within 3 months of the completion date of each such test.

SYNCHRONOUS GENERATING UNITS

- 7.16 The testing requirements in paragraphs 7.17 to 7.20 apply to machine-based synchronous **generating units**.

GENERATING UNIT FREQUENCY RESPONSE

- 7.17 A **generator** must, for each of its **generating units** that is not in an **excluded generating station** that is not subject to a directive issued by the **Authority** under clause 8.38 of the **Code**, or is in a **generating station** subject to a determination under clause 8.76 of the **Code**:
- (a) test the trip frequencies and trip time delays of the **generating unit's** analogue over-frequency functions and analogue under-frequency relays at least once every 4 years; and
 - (b) test the trip frequencies and trip time delays of the **generating unit's** non-self monitoring digital over-frequency relays and non-self monitoring digital under-frequency relays at least once every 4 years; and
 - (c) test the trip frequencies and trip time delays of the **generating unit's** self monitoring digital over-frequency relays and self monitoring digital under-frequency relays at least once every 10 years; and
 - (d) based on the tests carried out in accordance with paragraph 7.17(a), (b) or (c) provide a verified set of under-frequency trip settings and time delays to the **system operator** in an updated **asset capability statement** within 3 months of the completion date of each such test; and
 - (e) based on the tests carried out in accordance with paragraph 7.17(a), (b) or (c), provide a verified set of over-frequency trip settings and time delays to the **system operator** in an updated **asset capability statement** within 3 months of the completion date of each such test.

GENERATING UNIT FREQUENCY CONTROL SYSTEM

- 7.18 A **generator** must, for each of its **generating units** that is not in an **excluded generating station** that is not subject to a directive issued by the **Authority** under clause 8.38 of the **Code**, or is in a **generating station** subject to a determination under clause 8.76 of the **Code**:
- (a) test the response of the **generating unit's** mechanical or analogue speed governor and/or mechanical or analogue frequency **control system** at least once every 5 years; and
 - (b) test the response of the **generating unit's** digital or electro-hydraulic frequency **control system** at least once every 10 years; and
 - (c) based on the tests carried out in accordance with paragraph 7.18(a) or (b), provide a verified set of modelling parameters and governor or frequency **control system** response data to the **system operator** in an updated **asset capability statement** within 3 months of the completion date of each such test, including:
 - (i) a block diagram showing the mathematical representation of the frequency **control system**; and
 - (ii) a block diagram showing the mathematical representation of the turbine dynamics including non-linearity and the applicable fuel source; and
 - (iii) a parameter list showing gains, time constants and other settings applicable to the block diagrams.

GENERATING UNIT TRANSFORMER VOLTAGE CONTROL

- 7.19 A **generator** must, for each of its **generating units** that is not in an **excluded generating station** that is not subject to a directive issued by the **Authority** under clause 8.38 of the **Code**, or is in a **generating station** subject to a determination under clause 8.76 of the **Code**:
- (a) test the operation of the **generating unit** transformer's on-load tap changer analogue **control systems** at least once every 4 years; and
 - (b) test the operation of the **generating unit** transformer's on-load tap changer digital **control systems** at least once every 10 years; and
 - (c) based on the tests carried out in accordance with paragraph 7.19(a) or (b), provide a verified set of control parameters, including voltage set points, operating dead bands and response times, to the **system operator** in an updated **asset capability statement** within 3 months of the completion date of each such test.

GENERATING UNIT VOLTAGE RESPONSE AND CONTROL

- 7.20 A **generator** must, for each of its **generating units** that is not in an **excluded generating station** that is not subject to a directive issued by the **Authority** under clause 8.38 of the **Code**, or is in a **generating station** subject to a determination under clause 8.76 of the **Code** :
- (a) test the modelling settings and voltage response of the **generating unit's** analogue voltage **control system** at least once every 5 years; and
 - (b) test the modelling settings and voltage response of the **generating unit's** digital voltage **control system** at least once every 10 years; and
 - (c) based on the tests carried out in accordance with paragraph 7.20(a) or (b), provide a verified set of modelling parameters and voltage response data to the **system operator** in an updated **asset capability statement** within 3 months of the completion date of each such test, including:
 - (i) a block diagram showing the mathematical representation of the voltage **control system**; and
 - (ii) a parameter list showing gains, time constants and other settings applicable to the block diagrams.

GENERATING UNIT PRODUCING POWER FROM WIND OR SOLAR IRRADIANCE OR A BESS

- 7.21 The testing requirements in paragraphs 7.22 to 7.26 apply to **generating units** that produce power from wind, solar irradiance or a **BESS**.

GENERATING UNIT FREQUENCY RESPONSE

- 7.22 A **generator** must, for each of its **generating units** that is not in an **excluded generating station** that is not subject to a directive issued by the **Authority** under clause 8.38 of the **Code**, or is in a **generating station** subject to a determination under clause 8.76 of the **Code**:
- (a) confirm the trip frequencies and trip time delays of non-self monitoring digital over-frequency protection functions and non-self monitoring digital under-frequency protection functions for the **generating unit** at least once every 4 years; and
 - (b) confirm the trip frequencies and trip time delays of self monitoring digital over-frequency protection functions and self monitoring digital under-frequency protection functions for the **generating unit** at least once every 10 years; and
 - (c) based on a confirmation of settings in accordance with paragraphs 7.22(a) or (b), provide a set of under-frequency and over-frequency trip settings and time delays to the **system operator** in an updated **asset capability statement** within 3 months of the completion date of each such test.

GENERATING STATION FREQUENCY RESPONSE

- 7.23 A **generator** must, for each of its **generating stations** that is not an **excluded generating station** that is not subject to a directive issued by the **Authority** under clause 8.38 of the **Code**, or is subject to a determination under clause 8.76 of the **Code**, and has frequency protection relays installed at the station level:
- (a) test the trip frequencies and trip time delays of the **generating station's** analogue over-frequency relays and analogue under-frequency relays at least once every 4 years; and
 - (b) test the trip frequencies and trip time delays of the **generating station's** non-self monitoring digital over-frequency relays and non-self monitoring digital under-frequency relays at least once every 4 years; and
 - (c) test the trip frequencies and trip time delays of the **generating station's** self monitoring digital over-frequency relays and self monitoring digital under-frequency relays at least once every 10 years; and
 - (d) based on a test carried out in accordance with any of paragraphs 7.23(a) to (c) provide a verified set of under-frequency and over-frequency trip settings and time delays to the **system operator** in an updated **asset capability statement** within 3 months of the completion date of each such test.

GENERATING STATION FREQUENCY CONTROL SYSTEM

- 7.24 A **generator** must, for each of its **generating stations** that is not an **excluded generating station** that is not subject to a directive issued by the **Authority** under clause 8.38 of the **Code**, or is subject to a determination under clause 8.76 of the **Code**:
- (a) test the response of each frequency **control system** used for the **generating station** at least once every 10 years; and
 - (b) unless agreed otherwise with the **system operator**, immediately following a change to the settings or firmware for the frequency **control system** used for the **generating station**, test the response of each frequency **control system** used for the **generating station** where the change to the control settings or firmware has the potential to materially affect the performance of the frequency response of the **generating station**; and
 - (c) based on a test carried out in accordance with paragraph 7.24(a) or (b), provide a verified set of modelling settings and frequency **control system** response data to the **system operator** in an updated **asset capability statement** within 3 months of the completion date of each such test, including:
 - (i) a block diagram showing the mathematical representation of the frequency **control system**; and

- (ii) a block diagram showing the mathematical representation of the power converter and its electrical control; and
- (iii) a verified set of control settings and relevant firmware version identifiers for the frequency **control system** used for the **generating station**.

GENERATING STATION TRANSFORMER VOLTAGE CONTROL

7.25 A **generator** must, for each of its **generating stations** that is not an **excluded generating station** that is not subject to a directive issued by the **Authority** under clause 8.38 of the **Code**, or is subject to a determination under clause 8.76 of the **Code** :

- (a) test the operation of the **generating station** transformers' on-load tap changer analogue **control systems** at least once every 4 years; and
- (b) test the operation of the **generating station** transformers' on-load tap changer digital **control systems** at least once every 10 years; and
- (c) based on a test carried out in accordance with paragraph 7.25(a) or (b), provide a verified set of control settings, including voltage set points, operating dead bands and response times, to the **system operator** in an updated **asset capability statement** within 3 months of the completion date of each such test.

GENERATING STATION VOLTAGE RESPONSE AND CONTROL

7.26 A **generator** must, for each of its **generating stations** that is not an **excluded generating station** that is not subject to a directive issued by the **Authority** under clause 8.38 of the **Code**, or is subject to a determination under clause 8.76 of the **Code**:

- (a) test the response of each voltage **control system** used for the **generating station** at least once every 10 years; and
- (b) unless agreed otherwise with the **system operator**, immediately following a change to the control settings or firmware of the **control system** used for the **generating station**, test the response of each voltage **control system** used for the **generating station** where the change to the control settings or firmware has the potential to materially affect the performance of the voltage response of the **generating station**; and
- (c) based on a test carried out in accordance with paragraph 7.26(a) or (b), provide a verified set of modelling parameters and voltage response data to the **system operator** in an updated **asset capability statement** within 3 months of the completion date of each such test, including:
 - (i) a block diagram showing the mathematical representation of the voltage **control system**; and
 - (ii) a parameter list showing gains, time constants and other settings applicable to the block diagrams; and

- (iii) a verified set of control settings and relevant firmware version identifiers for the voltage **control system**.

NORTH ISLAND CONNECTED ASSET OWNER AUTOMATIC UNDER-FREQUENCY LOAD SHEDDING SYSTEM PROFILES AND TRIP SETTINGS

7.27 A North Island **connected asset owner** must:

- (a) provide the profile information described in clause 7(9) of **Technical Code B** of Schedule 8.3 of the **Code** to the **system operator** in an updated **asset capability statement** at least once every year; and
- (b) test the operation of each of its analogue **automatic under-frequency load shedding** systems at least once every 4 years; and
- (c) test the operation of each of its non-self monitoring digital **automatic under-frequency load shedding** systems at least once every 4 years; and
- (d) test the operation of each of its self monitoring digital **automatic under-frequency load shedding** systems at least once every 10 years; and
- (e) based on a test carried out in accordance with any of paragraphs 7.27(b) to (d), provide a verified set of trip settings and time delays to the **system operator** in an updated **asset capability statement** within 3 months of the completion date of each such test.

SOUTH ISLAND GRID OWNER AUTOMATIC UNDER-FREQUENCY LOAD SHEDDING SYSTEMS PROFILES AND TRIP SETTINGS

7.28 A South Island **grid owner** must:

- (a) provide the profile information described in clause 7(9) of **Technical Code B** of Schedule 8.3 of the **Code** to the **system operator** in an updated **asset capability statement** at least once every year; and
- (b) test the operation of each of its analogue **automatic under-frequency load shedding** systems at least once every 4 years; and
- (c) test the operation of each of its non-self monitoring digital **automatic under-frequency load shedding** systems at least once every 4 years; and
- (d) test the operation of each of its self monitoring digital **automatic under-frequency load shedding** systems at least once every 10 years; and
- (e) based on a test carried out in accordance with any of paragraphs 7.28(b) to (d), provide a verified set of trip settings and time delays to the **system operator** in an updated **asset capability statement** within 3 months of the completion date of each such test.

GRID OWNER TRANSFORMER VOLTAGE RANGE

7.29 A **grid owner** must:

- (a) test the operation of each of its transformer's on-load tap changer analogue **control systems** at least once every 4 years; and
- (b) test the operation of each of its transformer's on-load tap changer digital **control systems** at least once every 10 years; and
- (c) based on a test carried out in accordance with paragraph 7.29(a) or (b), provide a verified set of control settings, including voltage set points, operating dead bands and response times, to the **system operator** in an updated **asset capability statement** within 3 months of the completion date of each such test.

GRID OWNER SYNCHRONOUS COMPENSATORS

7.30 A **grid owner** must:

- (a) test each of its synchronous compensator's analogue and electromechanical voltage **control systems** at least once every 5 years; and
- (b) test each of its synchronous compensator's digital voltage **control systems** at least once every 10 years; and
- (c) based on a test carried out in accordance with paragraph 7.30(a) or (b), provide a verified set of modelling settings and voltage response data to the **system operator** in an updated **asset capability statement** within 3 months of the completion date of each such test, including:
 - (i) a block diagram showing the mathematical representation of the voltage **control system**; and
 - (ii) a detailed functional description of the voltage **control system** in all modes of control; and
 - (iii) a parameter list showing gains, time constants, limiters and other settings applicable to the block diagrams.

HVDC LINK FREQUENCY CONTROL AND PROTECTION

7.31 The **HVDC owner** must:

- (a) test the operation of each of the **HVDC link's** analogue **control systems** at least once every 4 years; and
- (b) test the operation of each of the **HVDC link's** digital **control systems** at least once every 10 years; and
- (c) test the operation of each of the **HVDC link's** analogue protection systems at least once every 4 years; and

- (d) test the operation of each of the **HVDC link's** digital protection systems at least once every 10 years; and
- (e) test the modulation functions on the **HVDC link** at least once every 10 years; and
- (f) based on a test carried out in accordance with paragraph 7.31(a) or (b), provide a set of **control system** test results and verified modelling settings to the **system operator** in an updated **asset capability statement** within 3 months of the completion date of each such test; and
- (g) based on a test carried out in accordance with paragraph 7.31(c) or (d), provide a set of protection system test results to the **system operator** in an updated **asset capability statement** within 3 months of the completion date of each such test; and
- (h) based on a test carried out in accordance with paragraph 7.31(e), provide a set of modulation function test results to the **system operator** in an updated **asset capability statement** within 3 months of the completion date of each such test, including:
 - (i) a block diagram showing the mathematical representation of the **HVDC link**; and
 - (ii) a parameter list showing gains, time constants, limiters and other settings applicable to the block diagram; and
 - (iii) a detailed functional description of the components of the **HVDC link** and how they interact in each mode of control.

Chapter 8: Operational Communication Requirements



- 8.1 This Chapter applies to:
- assets in asset group 2;** and
 - assets not in **asset group 1** or **asset group 2** that are referred to specifically in this Chapter; and
 - the **asset owners** of these **assets**.
- 8.2 This Chapter specifies the minimum requirements for operational communications for the purposes of clause 8.25(3) of the **Code**.
- 8.3 **Asset owners**, except owners of **excluded generating stations**, must comply with the minimum requirements described in this Chapter, to assist the **system operator** to plan to comply, and to comply, with the **principal performance obligations**.
- 8.4 The **system operator** may require that a **generator** comply with some or all of the requirements in this Chapter in respect of an **excluded generating station** if the **system operator** reasonably considers it necessary to assist the **system operator** to plan to comply, and to comply, with the **principal performance obligations**.

GENERAL REQUIREMENTS FOR OPERATIONAL COMMUNICATIONS

- 8.5 Each voice or electronic communication between the **system operator** and an **asset owner** must be logged by the **system operator** and the **asset owner**. Unless agreed otherwise between the **system operator** and the **asset owner**, every voice instruction must be repeated back by the person receiving the instruction and confirmed by the person giving the instruction before the instruction is actioned.
- 8.6 The **system operator** and each **asset owner** must nominate and advise each other of the preferred points of contact and the alternative points of contact to be used by the **system operator** and the **asset owner**. Each **asset owner** must also nominate and advise the **system operator** of the person to receive instructions and **formal notices** as set out in **Technical Code B** of Schedule 8.3 of the **Code**. The preferred points of contact must include those to be used when the **system operator** instructs the **asset owner**, when the **system operator** sends **formal notices** to the **asset owner** and when the **asset owner** contacts the **system operator**. The alternative points of contact must be used only if the preferred points of contact are not available.
- 8.7 The **grid owner** and each other **asset owner** must nominate and advise each other of the preferred points of contact and the alternative points of contact to

be used by the **grid owner** and the other **asset owner** for the purpose of communications regarding the availability of the **grid owner's** data transmission communications. The alternative points of contact must only be used if the preferred points of contact are not available.

SPECIFIC REQUIREMENTS FOR VOICE COMMUNICATIONS

- 8.8 Each **asset owner** must have in place a primary means of communicating by voice between the **control room** of the **asset owner** and the **system operator**. The primary means of voice communication must use either:
- (a) the **grid owner's** speech network; or
 - (b) a widely available public switched telephone network that operates in real-time and in full duplex mode.
- 8.9 An **asset owner** must have in place a backup means of communicating by voice between the **control room** of the **asset owner** and the **system operator**. The backup means of voice communication:
- (a) must be approved by the **system operator** (such approval not to be unreasonably withheld); and
 - (b) may include, but is not limited to, satellite phone or cellular phone; and
 - (c) may be used only if the primary means of voice communication described in paragraph 8.8 is unavailable or otherwise with the agreement of the **system operator**.
- 8.10 An **asset owner** who has a **control room** with, at any time, operational control of more than 299 MW of **injection**, **offtake**, or power flow must have two or more backup means of voice communication between the **control room** of the **asset owner** and the **system operator**, each of which must meet the requirements of paragraph 8.9.

SPECIFIC REQUIREMENTS FOR TRANSMITTING INFORMATION

- 8.11 An **asset owner** must transmit information between its **control room** and the **system operator** in written form.
- 8.12 Despite paragraph 8.11, an **asset owner** may request the **system operator** to approve an alternative means of transmitting information (such approval not to be unreasonably withheld).
- 8.13 An **asset owner** must have in place a backup means of transmitting information. The backup means of transmitting information:
- (a) must be approved by the **system operator** (such approval not to be unreasonably withheld); and
 - (b) may include, but is not limited to, voice communication or email; and
 - (c) may be used only if the primary means of transmitting information described in paragraph 8.11 or 8.12 is unavailable or otherwise with the agreement of the **system operator**.

SPECIFIC REQUIREMENTS FOR DATA TRANSMISSION COMMUNICATION

- 8.14 An **asset owner** (other than a **grid owner**) must have in place either:
- (a) a primary means of transmitting data between the **assets** of the **asset owner** and a **SCADA** remote terminal unit of a **grid owner**; or
 - (b) if approved by the **system operator** (such approval not to be unreasonably withheld), a primary means of transmitting data between the **assets** of the **asset owner** and the **system operator**.
- 8.15 A **grid owner** must have in place a primary means of transmitting data between the **assets** of the **grid owner** and the **system operator**.
- 8.16 An **asset owner** must have in place a backup means of transmitting data for each type of applicable indication and measurement specified in paragraph 8.23. The backup means of data transmission communication:
- (a) must be approved by the **system operator** (such approval not to be unreasonably withheld); and
 - (b) may include, but is not limited to, use of voice communication or document transmission communication; and
 - (c) may only be used if the primary means of data transmission communication described in paragraph 8.14 or 8.15 is unavailable or otherwise with the agreement of the **system operator**.

AVAILABILITY OF PRIMARY MEANS OF COMMUNICATION

- 8.17 An **asset owner** must use reasonable endeavours to ensure that the primary means of communication described in paragraphs 8.8, 8.11, 8.12, 8.14 and 8.15 is available continuously.
- 8.18 If the primary means of communication described in paragraphs 8.8, 8.11, 8.12, 8.14 and 8.15 is unavailable, the **asset owner** must use reasonable endeavours to restore availability of the primary means of communication as soon as practicable.

NOTIFICATION OF PLANNED OUTAGES OF PRIMARY MEANS OF COMMUNICATION

- 8.19 An **asset owner** must give written notice to the **system operator** of any planned outage of a primary means of communication described in paragraphs 8.8, 8.11, 8.12, 8.14, 8.15.

PERFORMANCE REQUIREMENTS FOR INDICATIONS AND MEASUREMENTS

- 8.20 An **asset owner** must provide the relevant indications and measurements shown in the *Required Indications and Measurements* section below (starting at paragraph 8.23) to the **system operator** in accordance with paragraphs 8.14 to 8.16. The **system operator** may require the **asset owner** to provide additional information if, in the reasonable opinion of the **system operator**,

such information is required for the **system operator** to plan to comply, and to comply, with the **principal performance obligations**.

- 8.21 An **asset owner** must use reasonable endeavours to ensure that the accuracy of the measurements it provides to the **system operator** in accordance with paragraph 8.20 complies with the *Required Indications and Measurements* section below (starting at paragraph 8.23).
- 8.22 Each indication and measurement provided in accordance with paragraph 8.20 must be updated at the **grid owner's SCADA** remote terminal or the **system operator's** interface unit at least once every 8 seconds when provided by the primary means of data transmission communications.

REQUIRED INDICATIONS AND MEASUREMENTS

GENERAL REQUIREMENTS

- 8.23 A **generator, grid owner, and connected asset owner** must provide the indications and measurements listed in Table A below and to the extent applicable, provide the indications and measurements listed in Tables B-J below.
- 8.24 If net (or gross) measurements are required in any of Tables A-J below, the use of **scaling factors** together with the provision of the relevant gross (or net) values is acceptable with the **system operator's** approval (such approval not to be unreasonably withheld). Each **generator** and **connected asset owner** must provide **scaling factors** to the **grid owner** so that the **grid owner** can apply the adjustment at the **SCADA** server.
- 8.25 If numerical values are required in any of Tables A-J below, the accuracy of numerical values must be measured at the input terminal of the remote terminal unit of the **grid owner**, under normal operating conditions at full scale.

Table A: General Requirements, Applicable to all Assets

Indication or measurement	Values required
Grid interface circuit breaker status	Open/closed/in transition/indication error (exclude time delays for circuit breaker indications, as they are time tagged by the system operator to less than 10 ms)
Grid interface disconnecter status	Open/closed/in transition/indication error
Special protection scheme status	Enabled/disabled/summer/winter
Dynamic reactive power compensation devices MVar	Import and export ($\pm 2\%$ accuracy; required only if the dynamic reactive power compensation device has a maximum continuous rating equal to or greater than 5 MVar)
Shunt capacitors MVar	Import and export ($\pm 2\%$ accuracy; required only if shunt capacitor bank has a maximum continuous rating equal to or greater than 5 MVar)
Grid interface auto reclose status	Enabled/disabled/operated/locked out

GENERATOR-SPECIFIC REQUIREMENTS

8.26 A **generator** must provide the indications and measurements listed in Table B below.

Table B: Specific Requirements for Generators

Indication or measurement	Values required
Station net MW	Import and export ($\pm 2\%$ accuracy)
Station net MVar	Import and export ($\pm 2\%$ accuracy)
Frequency Control Operation Mode	Enabled/disabled ²
Voltage Control Operation Mode	Enabled/disabled
Power System Stabiliser or Power Oscillation Damper Status	Enabled/disabled
Generating Station HV Busbar Voltage (if HV busbar is not owned by a grid owner)	kV ($\pm 2\%$ accuracy)
Circuit Amps (if circuit is not owned by a grid owner)	Current at each termination point of a circuit
Circuit MW (if circuit is not owned by a grid owner)	MW at each termination point of a circuit
Circuit MVar (if circuit is not owned by a grid owner)	MVar at each termination point of a circuit

8.27 If the **asset** is a synchronous **generating unit**, the **asset owner** must provide the indications and measurements listed in Table C below.

Table C: Specific Requirements for Synchronous Generating Units

Indication or measurement	Values required
Generating unit gross MW	Import and export ($\pm 2\%$ accuracy)
Generating unit gross MVar	Import and export ($\pm 2\%$ accuracy)
Generating unit circuit breaker status	Open/closed/in transition/indication error
Generating unit Terminal Voltage kV	kV ($\pm 2\%$ accuracy)

8.28 If the **asset** is one or more **generating units** producing power from wind or solar irradiance or a **BESS**, the **asset owner** must provide the indications and measurements listed in Table D below.

Table D: Specific Requirements for Generating Units Producing Power from Wind or Solar Irradiance or a BESS

Indication or measurement	Values required
----------------------------------	------------------------

² The exact values required depend on the design of the frequency **control system**. The principle is to provide indications that are required to accurately model frequency response in real-time. For example, if a feed-forward loop is enabled/disabled in real-time, an indication needs to be provided. Specifics should be discussed with the **system operator** during the **commissioning** process.

Generating system net MW	Import and export ($\pm 2\%$ accuracy)
Generating system net MVar	Import and export ($\pm 2\%$ accuracy)
Generating system circuit breaker status	Open/closed/in transition/indication error
Number of active inverters or wind turbines in the generating station	
Station available MW	The available active power if generating the maximum active power possible given the available fuel resource
Station MV busbar voltage (kV) (only if applicable; see Appendix A for further guidance)	

8.29 If the **asset** is a **BESS**, the **asset owner** must provide the indications and measurements listed in Table E below.

Table E: Specific Requirements for Battery Energy Storage Systems

Indication or measurement	Values required
Generating station state of charge (%)	Must be the energy stored in the BESS as a percentage of nameplate rated capacity, irrespective of any state of charge limits

8.30 If the **asset** is one or more solar photovoltaic **generating units**, the **asset owner** must provide the indications and measurements listed in Table F below.

Table F: Specific Requirements for Solar Photovoltaic Generation Assets

Indication or measurement	Values required
Solar irradiance horizontal (W/m ²)	Must be the average of all sensors on the site

8.31 If the **asset** is one or more wind turbines, the **asset owner** must provide the indications and measurements listed in Table G below.

Table G: Specific Requirements for Wind Generation Assets

Indication or measurement	Values required
Wind speed at nacelle height (km/h)	Must be an average of every nacelle or group of nacelles

8.32 If the **asset** is hybrid plant, the **asset owner** must provide the indications and measurements listed in Table H below.

Table H: Specific Requirements for Hybrid Plant

Indication or measurement	Values required
Generating station intermittent generation MW	Import and export ($\pm 2\%$ accuracy)

Generating station BESS Injection/Load MW	Import and export ($\pm 2\%$ accuracy)
--	---

GRID OWNER-SPECIFIC REQUIREMENTS

8.33 A **grid owner** must provide the indications and measurements listed in Table I below in respect of **assets** connected to, or forming part of, the **grid**.

Table I: Grid-Owner Specific Requirements

Indication or measurement	Values required
Grid interface auto reclose status	Enabled/disabled/operated/locked out
Grid interface MW	Import and export ($\pm 2\%$ accuracy)
Grid interface MVar	Import and export ($\pm 2\%$ accuracy)
Circuit Amps	Current at each termination point of a circuit
Circuit MW	MW at each termination point of a circuit
Circuit MVar	MVar at each termination point of a circuit
Tap positions for interconnecting transformers and supply transformers with on-load tap changers	Tap position for all windings including tapped tertiaries
Tap positions for interconnecting transformers and supply transformers with off-load tap changers	Tap position for all windings including tapped tertiaries (indication required within 5 minutes of status change)
Busbar voltage	kV ($\pm 2\%$ accuracy)
HVDC modulation status	Frequency stabiliser/spinning reserve sharing/Haywards frequency control/AC transient voltage support
Reactive Power Controller status	Enabled/disabled
Reactive Power Controller setpoint	kV or MVar

CONNECTED ASSET OWNER-SPECIFIC REQUIREMENTS

8.34 A **connected asset owner** must provide the indications and measurements listed in Table J below and use reasonable endeavours to achieve the accuracies for those indications and measurements in Table J below.

Table J: Connected Asset Owner-Specific Requirements

Indication or measurement	Values required
Controllable load available MW	Any controllable load that is not currently off or armed for interruptible load Actual or calculated ($\pm 5\%$ accuracy) Per GXP unless agreed otherwise by the asset owner and the system operator
Controllable load currently off MW	Actual or calculated ($\pm 5\%$ accuracy)

	Per GXP unless agreed otherwise by the asset owner and the system operator
Controllable load armed for interruptible load MW	Actual ($\pm 2\%$ accuracy) Per GXP unless agreed otherwise by the asset owner and the system operator

Chapter 9: High Speed Data Requirements

- 9.1 This Chapter applies to **assets** in **asset group 2** and their **asset owners**.
- 9.2 This Chapter specifies the minimum requirements for **high-speed monitors** that **asset owners** must install for the purposes of clause 8(2)(c) of **Technical Code A** of Schedule 8.3 of the **Code**.
- 9.3 An **asset owner** must install a **high-speed monitor** at each of its **generating stations** and provide event data from the **high-speed monitor** to the **system operator** for post-event analysis and routine testing requirements in accordance with Chapter 7.
- 9.4 The **asset owner** must submit **high-speed monitor** data to the **system operator** in either a csv, ascii, or COMTRADE format.
- 9.5 **High-speed monitor** data must include the values listed in Table K below.

Table K: High-Speed Monitor Data Requirements

Indication and Measurements	Notes
Generating station active power (MW)	Must provide all values other than frequency per-phase
Generating station reactive power (MVar)	
Generating station frequency (Hertz)	
Generating station transformer HV voltage (kV)	
Generating station transformer HV current (A)	

- 9.6 **High-speed monitor** data recording must be triggered according to Table L below and must be global positioning system time stamped and recorded as follows:
- (a) pre-trigger, 10 seconds;
 - (b) post-trigger, 120 seconds;
 - (c) at a resolution of 20 milliseconds or better.

Table L: High-Speed Monitor Data Triggers

Trigger Type	Setting
Under-voltage	90% Nominal Voltage
Over-voltage	110% Nominal Voltage
Under-frequency	49.5 Hertz
Over-frequency	50.5 Hertz

Appendix A: Single Line Diagrams

This Appendix A shows the common topologies for different types of **generating plant**, and the **system operator's** interpretation of how the terms **generating station**, **generating unit** and **generating system** apply to these topologies.

Not all **generating stations** will use one of these topologies. An **asset owner** may discuss specific cases with the **system operator** during the **commissioning** process.

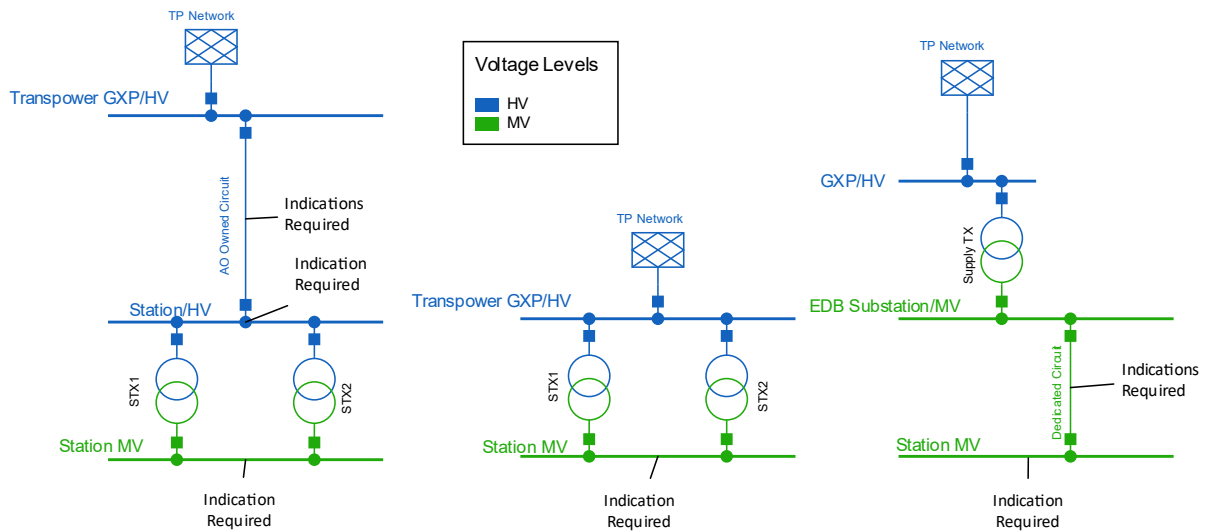

Figure A1: Typical configuration of different possible network connections with required circuit and busbar indications marked

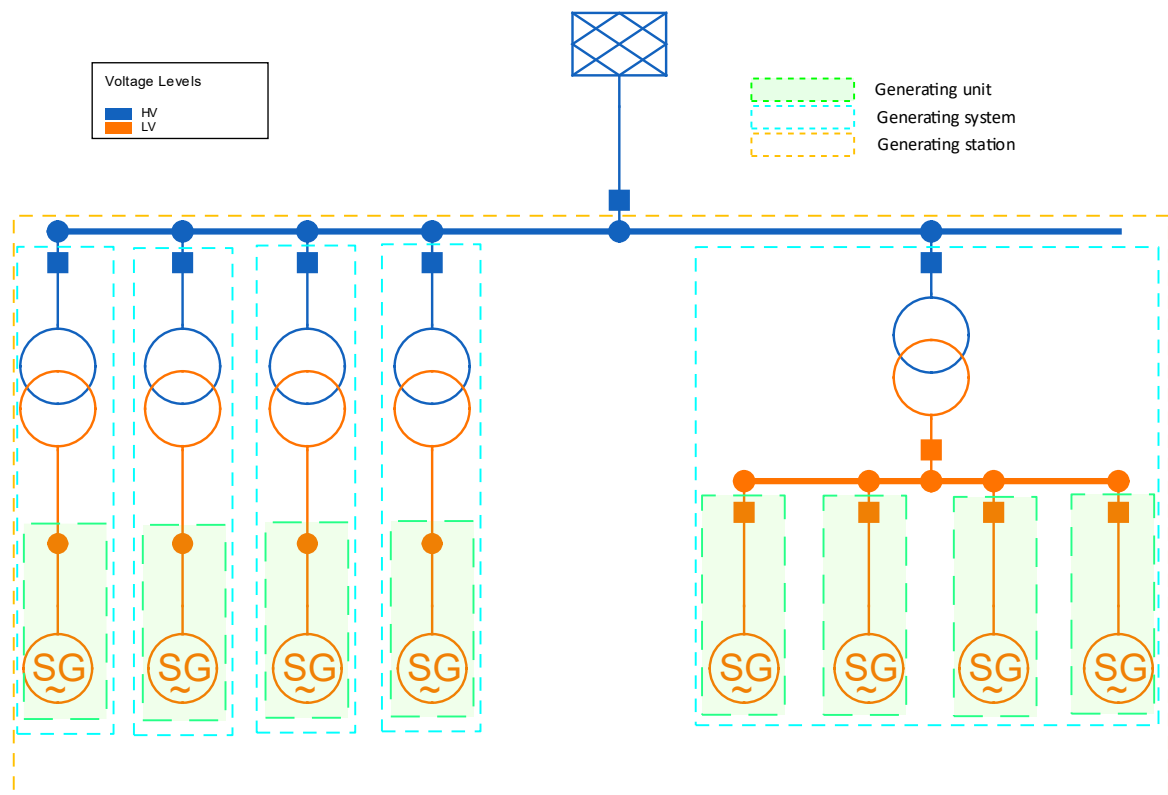

Figure A2: Typical configuration of synchronous generating stations

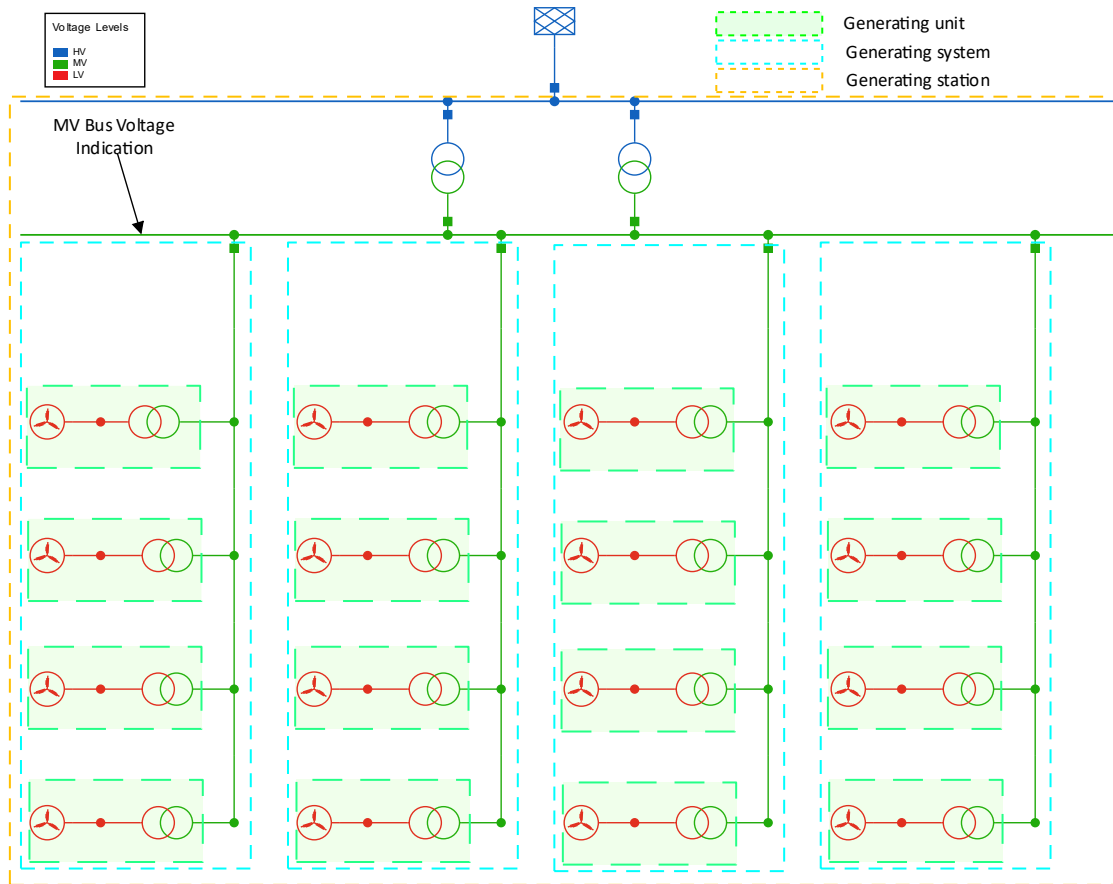

Figure A3: Typical configuration of a wind farm

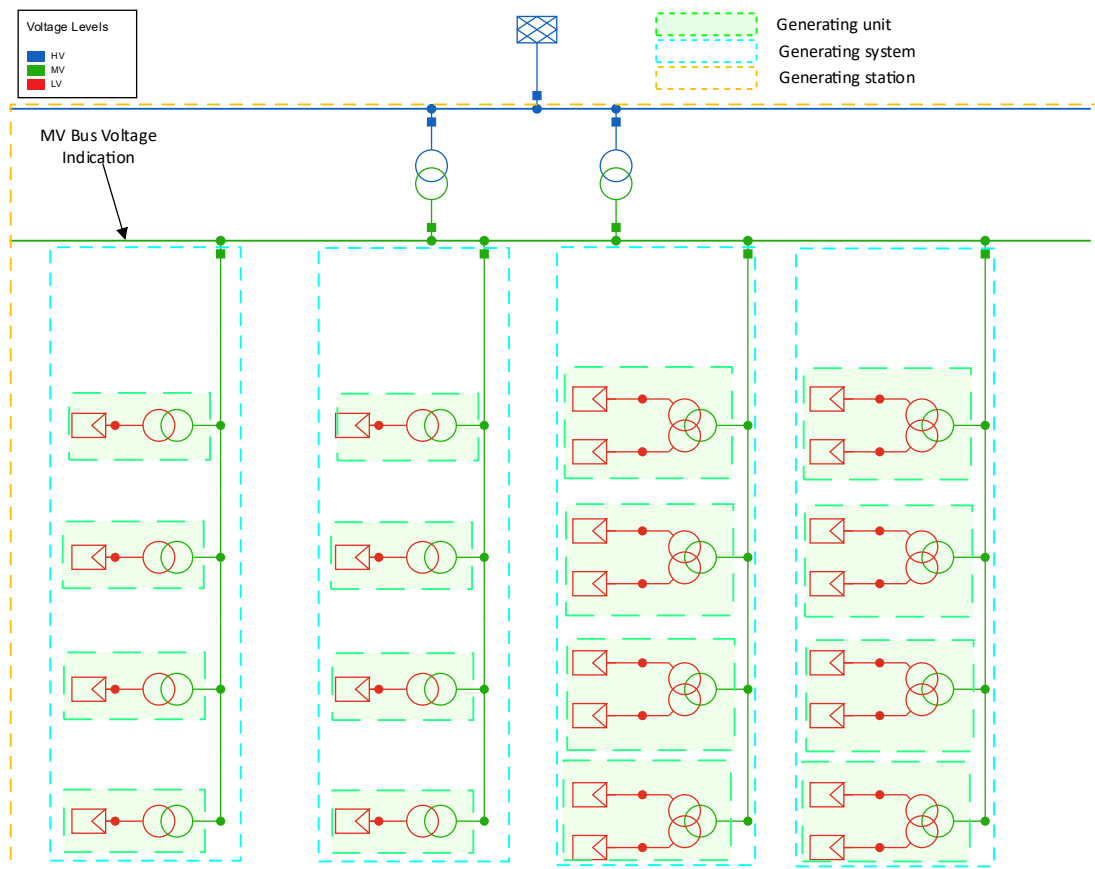

Figure A4: Typical configuration of a solar farm with central inverters

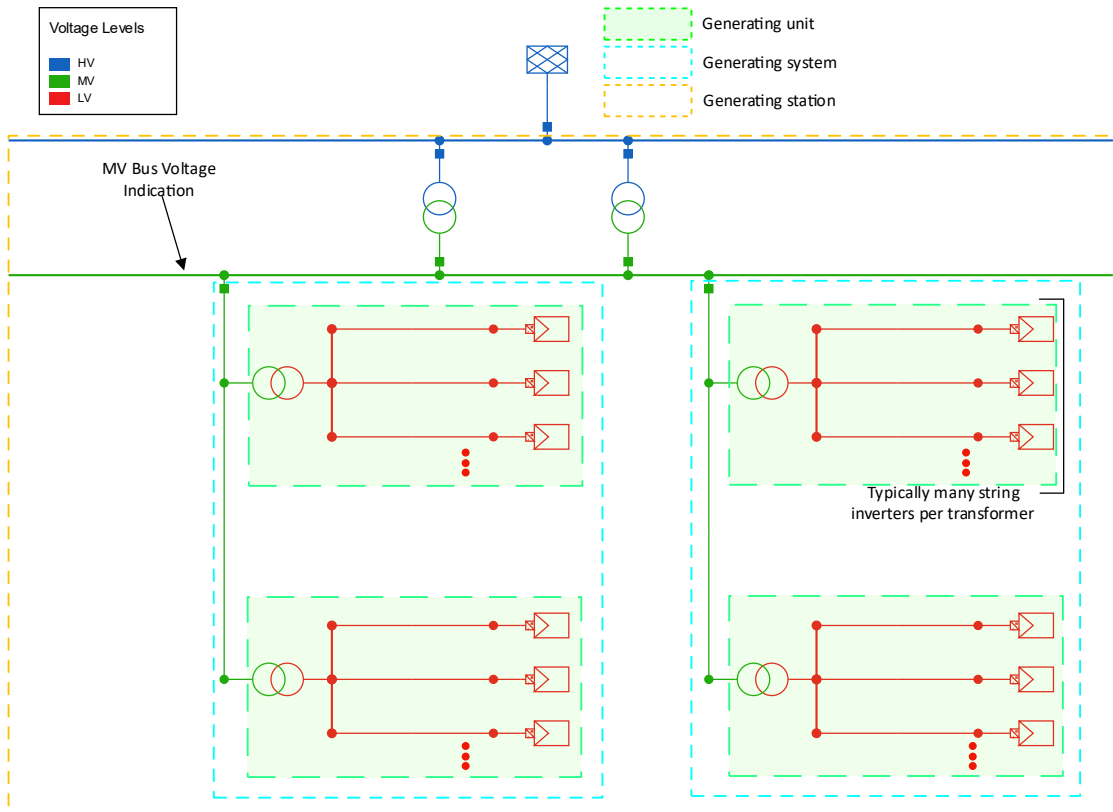

Figure A5: Typical configuration of a solar farm with string inverters

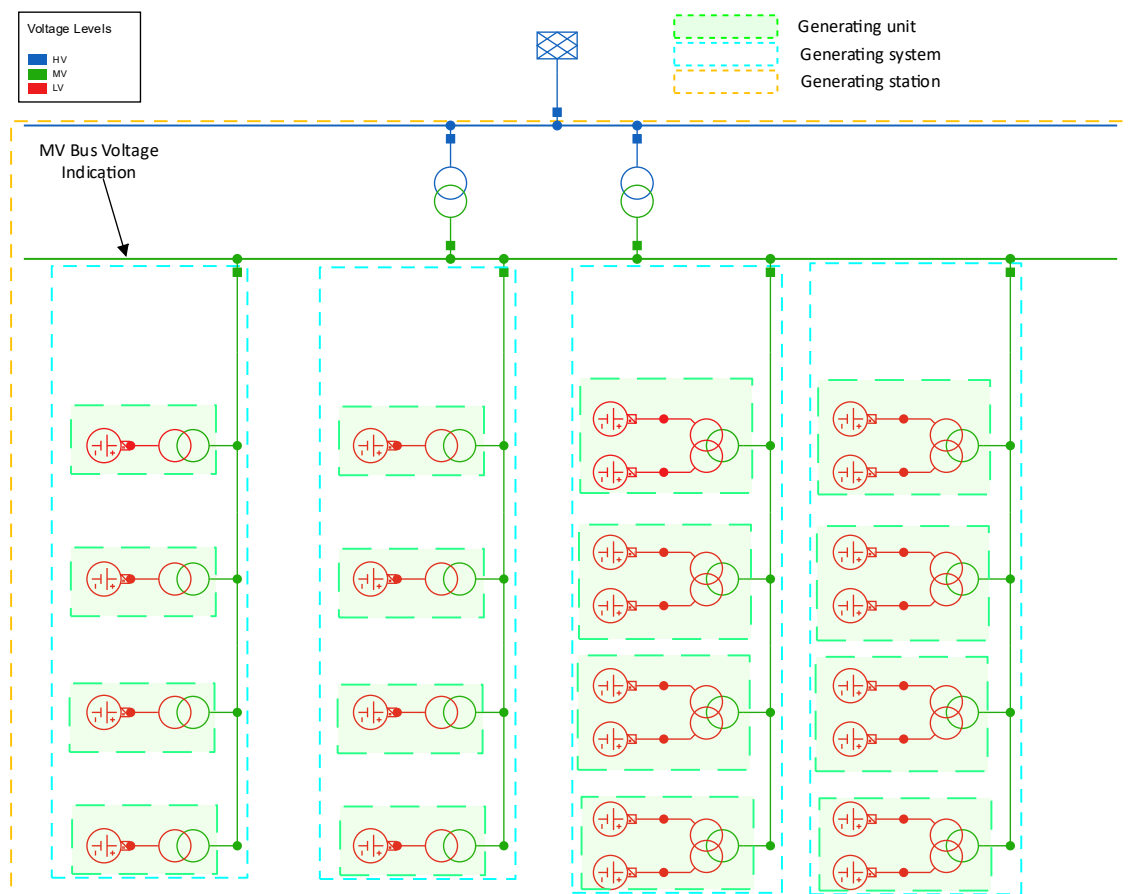

Figure A6: Typical configuration of a BESS

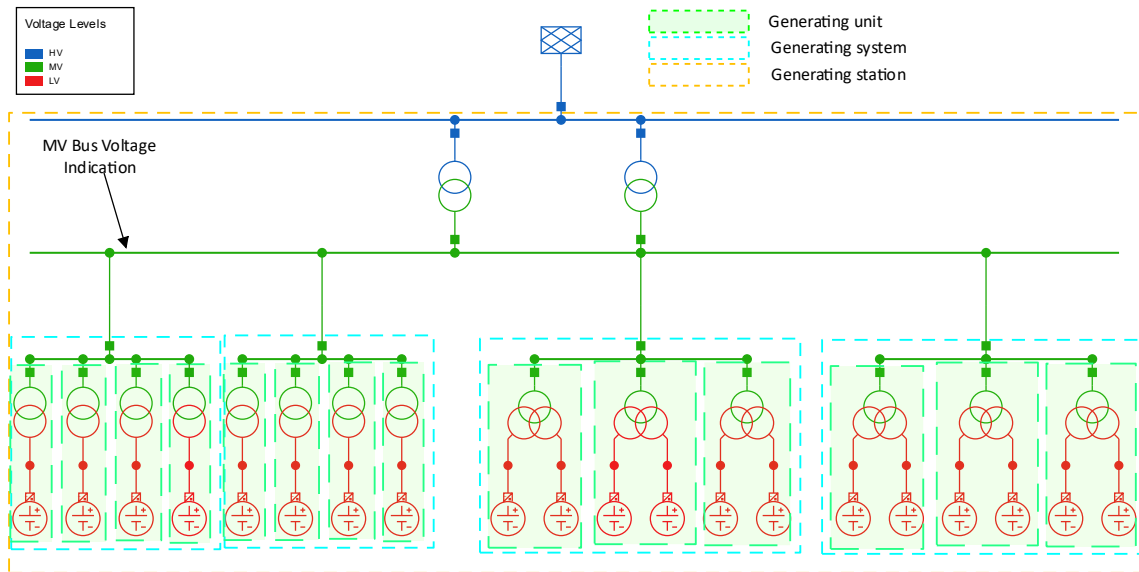

Figure A7: Another common configuration of a BESS

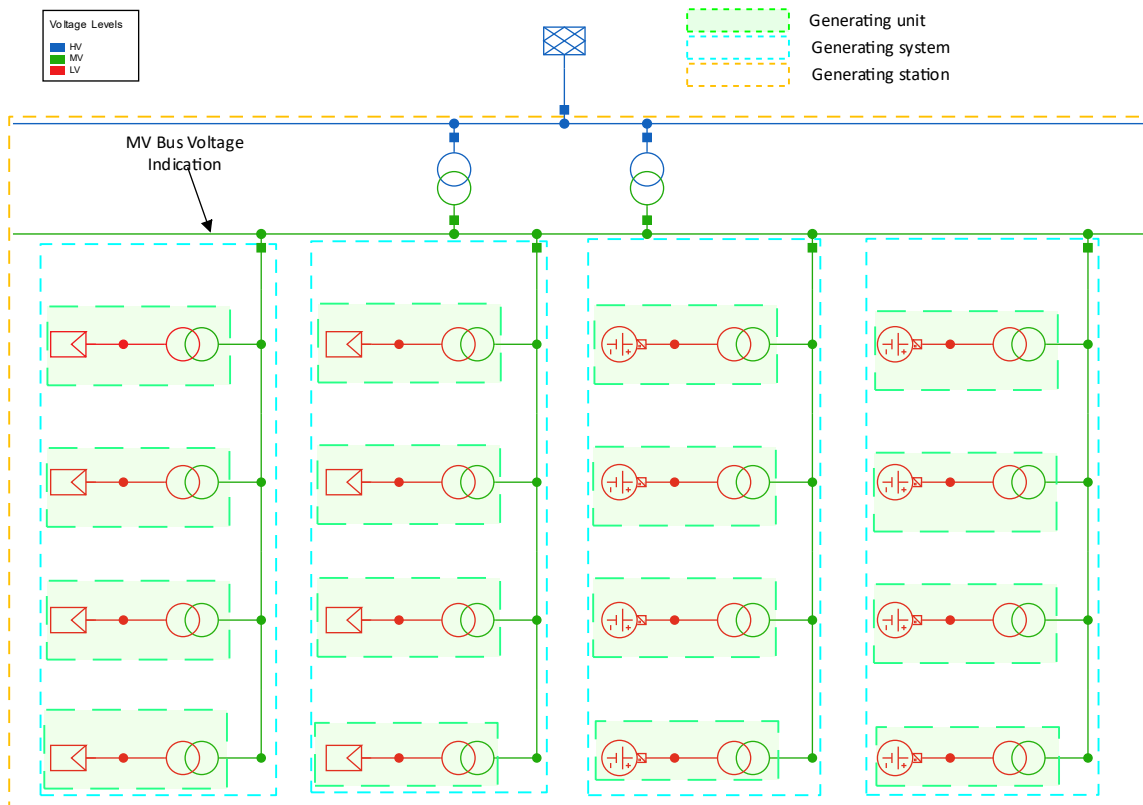

Figure A8: Typical configuration of an AC-coupled hybrid plant

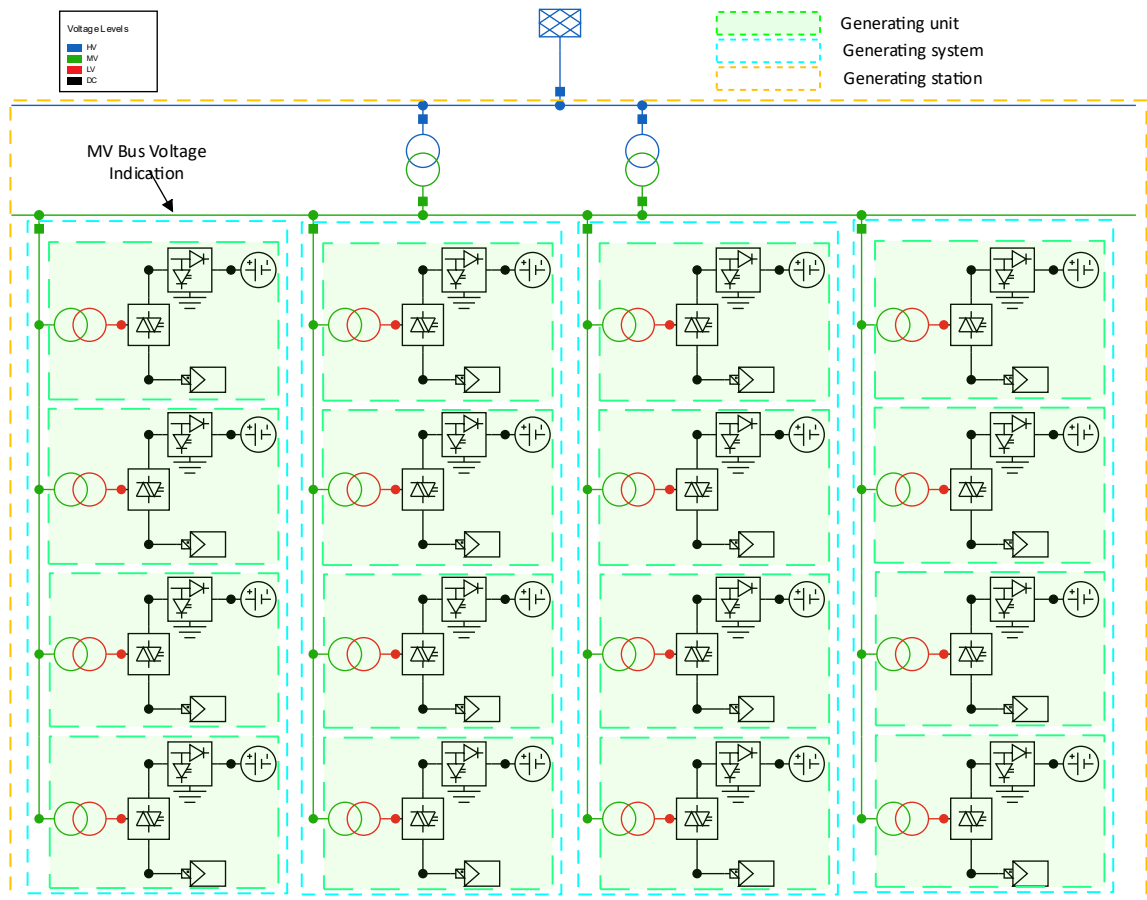

Figure A9: Typical configuration of a DC-coupled hybrid plant